

VOTRONIC

Mounting Instructions and Operating Manual for Battery Charger:

Automatic Charger Pb 1240 SMT 3B	Charging Capacity 12 V / 40 A	No. 3118
Automatic Charger Pb 1250 SMT 3B	Charging Capacity 12 V / 50 A	No. 3119
Automatic Charger Pb 1260 SMT 3B	Charging Capacity 12 V / 60 A	No. 3122
Automatic Charger Pb 2420 SMT 3B	Charging Capacity 24 V / 20 A	No. 6237
Automatic Charger Pb 2425 SMT 3B	Charging Capacity 24 V / 25 A	No. 6239
Automatic Charger Pb 2430 SMT 3B	Charging Capacity 24 V / 30 A	No. 6242



Please read this operating and installation manual thoroughly prior to connection and start-up.

NOTE: The values being indicated in parentheses () apply to 24 V operation.

All-automatic battery charger with 3 charging ports for intervention vehicles and special purpose vehicles, high-quality campers and the marine field.

VOTRONIC chargers of series "Pb SMT" distinguish by their compact design, low weight (high-frequency switching power supply, Switch Mode Technology), as well as full charging capacity - even in case of large deviations in the power supply (low voltage/overvoltage, sine curve, frequency).

Due to the intelligent microprocessor charging control with characteristic lines of charging „IU1oU2oU3“ and dynamic charging time calculation an automatic, quick and gentle full charging is ensured, as well as subsequent 100 % trickle charge of the connected batteries from any charging state. At the same time, simultaneous supply of 12 V (24 V) consumers, which are connected in parallel, is ensured or charging of very large batteries (depending on case of application).

Battery Ports and Charging Programs:

Charging port main battery „A“ (master), 3 charging programs selectable (see table 3), depending on the type of battery:

- „AGM“: Closed, gas-tight **AGM/fleece** batteries (absorbed glass mat, lead-fleece technology)
- „Gel“: Closed, gas-tight **Gel/dryfit** batteries (determined electrolyte)
- „Lead Acid“: Closed and open **acid/lead-acid** batteries, as well as **AGM** with indication of the charging voltage "14.4 V"

Charging Port Main Battery „B“, selectable charging programs depending on the type of battery (see table 4):

- „B = A“: Charging programs as battery A with parallel charging by integrated charging current distributor
- „B < A“: designed for charging of starter batteries (max. charging current also for the starter battery)

Auxiliary Charging Port Battery „C“:

Separate auxiliary charging port (12 V (24 V) /4 A) for support charging and trickle charge of the vehicle's starter battery with overcharge protection. It can also be used as signalling port for vehicle motor locking by external relays.

Further Characteristics of the Unit:

- The **charging voltage** being **free from peaks** is **controlled** in such a way, that any **overcharging** of the batteries is **excluded**.
- All-automatic Continuous Operation:** The charger may be connected continuously to the battery, thus keeping the full charge. Battery discharge in case of power failure is **avoided** (separation by safety relay).
- Battery regeneration** in case of extended stop periods: twice a week to avoid harmful acid accumulation.
- Parallel and Floating Operation:** In case of simultaneous consumption, charging of the battery is continued or trickle charging is effected. Calculation and control of the adaptation of the charging time is effected automatically by the charger.
- Unattended Charging:** Multiple protection against overload, overheating, overvoltage, short circuit, reverse battery, incorrect behaviour and back discharge of the battery by electronically controlled gradual reduction down to complete separation of charger and battery **by integrated safety relays**.
- Power Pack Function:** Allows supply of the consumers without battery (e. g. during battery replacement)
- Charging Cable Compensation:** Automatic compensation of voltage losses on the charging cables.
- Charging aid for totally discharged batteries:** Gentle preliminary charging of the battery to 8 V (16 V), followed by powerful support of the battery, if consumers should still be switched-on.
- Integrated On-board Mains Suppression Filter:** Unproblematic parallel operation of solar systems, wind and petrol-driven generators, dynamos etc. at one battery.
- Temperature Compensation:** In case of **low outside temperatures**, **full charging** of the weak battery is **improved** by automatic adaptation of the charging voltage to the battery temperature, and in case of summery temperatures **unnecessary battery load and gassing** will be avoided. Temperature Sensor (order No. 2001) is required.

Lifetime of the battery:



- Keep batteries cool; choose an appropriate location for installation.
- **Open acid batteries („maintenance-free according to EN / DIN“): Check the acid level periodically!**
- **Batteries being totally discharged should be recharged immediately, partially discharged batteries should be recharged fully as soon as possible to avoid sulphation!**
- **Store only fully charged batteries and recharge them periodically**, particularly in case of older, used batteries and in case of low and higher temperatures! If the grade of sulphation is not too intensive, the battery can recover part of the battery capacity after several charging/discharging cycles.
In contrast to other battery types, batteries on lead basis **do not have any** harmful memory effect. Consequently: In case of doubt, partially discharged batteries are to be **charged fully** as soon as possible.
- **Interruption of the Charging Process:**
In case of power failure, withdrawal of the mains plug or positioning of the unit switch to position "0" during the charging process, the charging process will be interrupted. The connected batteries **will not be** discharged by the charger. Thus, the charging process can be interrupted at any time.
In case of frequent interruptions, particularly before reaching full charge (LED „Battery Full“ is lighting **permanently**), the battery should be subject to an **occasional full charging cycle of 24 hours** for compensation of the charge.



Safety Regulations:

Appropriate Application:

The battery charger has been designed according to the valid safety regulations.

Appropriate application is restricted to:

1. **Charging of lead-acid, lead-gel or lead-AGM batteries of the indicated nominal voltage and the supply of the consumers being connected to these batteries in fixed installed systems with the indicated battery capacities and charging programs.**
2. **Connection to a shock-proof socket, which has been installed according to the valid technical regulations, protected with max. 16 A (if required mobile/stationary with a fault current breaker (FI) with a nominal residual current of 30 mA).**
3. **Connection in consideration of the indicated cable cross sections at the charger ports.**
4. **Fuses of the indicated capacity are to be provided near the battery to protect the cabling between battery and charger port.**
5. **Technically faultless condition.**
6. **Installation in a well-ventilated room, protected from rain, humidity, dust, aggressive battery gas, as well as in an environment being free from condensation water.**

Never use the unit at locations where the risk of gas or dust explosion exists!

- Open-air operation of the unit is not allowed.
- Lay the cables in a way, that damage is avoided and observe to fasten them tightly.
- Never lay 12 V (24 V) cables and 230 V mains supply cables into the same cable conduit (empty conduit).
- Check live cables or leads periodically for insulation faults, points of break, as well as loosened or overloaded connections and remedy eventual defects.
- The unit is to be disconnected from any connection prior to execution of electrically welding or work on the electric system.
- If the user is not able to draw from the manual, which characteristic values are valid for a unit or which regulations are to be observed, a specialist is to be consulted.
- The user/buyer is obliged to observe any construction and safety regulations.
- **The unit does not contain any parts, which can be replaced by the user.** Even after withdrawal of the mains plug, the unit may be **extremely live** for an extended period (particularly in case of failure).
- Keep children away from the charger and the batteries.
- Observe the safety regulations of the battery manufacturer; deaerate the battery room.
- Non-observance may result in injury or material damage.
- The warranty period is 24 months from the purchase date (against presentation of the sales slip or invoice).
- The warranty will be void in case of any inappropriate utilisation of the unit, if it is used beyond the technical specification, in case of improper operation or external intervention. We do not assume any liability for any damage resulting hereof. The liability exclusion is extended to any service being executed by third, which has not been ordered by us in writing. Service is to be effected exclusively by VOTRONIC Lauterbach.

Installation of the Unit:

Install the charger **near the batteries A and B (short charging cables)** at a clean, even and hard mounting surface, which is protected from moisture and humidity.

The unit can be installed in any position. Protect the unit from aggressive battery gases.

Despite the charger's high efficiency, heat is produced, which is brought out of the casing by means of the built-in fan. The vent holes of the unit should never be covered (minimum distance 10 cm) to ensure full charging capacity. Ensure sufficient **ventilation** in the **environment of the unit** so that the heat can be carried-off.

Otherwise, the unit might effect a slight reduction of the charging capacity in case of increased heating.

Solid and vibration reducing installation by means of the rubber feet. Never remove these rubber feet!

Start-up: Initial Battery Connections and Settings

Observe the connection plan as well as table 1 indicating the cables and +fuses!

1. Connect the main battery to the terminals „-com- ABC“ and „+A“ observing the correct polarity.
2. Setting of the **battery size(s)**, such as capacity (total A and B) in **Ah**: See **table 2**.
3. Setting of the **charging program** for battery type "A" (design): See **table 3**.
4. Setting of the **charging program** for battery type "B" (design): See **table 4**.
5. Set the slide switch „**AC Power Limit**“ to position „**Max.**“.





Insert the mains plug and position the **mains switch** (unit rear) to position „I“. The all-automatic charging process starts.

Table 1: Recommended lengths of charging cables, cable cross sections and +fuse capacities:

Lengths of charging cables -ABC and +A/+B	Pb 1240	Pb 1250	Pb 1260	Pb 2420	Pb 2425	Pb 2430
2x 1.0 -2.0 m	6 mm ²	10 mm ²	10 mm ²	6 mm ²	6 mm ²	6 mm ²
2x 1.5 -3.0 m	10 mm ²	16 mm ²	16 mm ²	10 mm ²	10 mm ²	10 mm ²
2x 2.5 -5.0 m	16 mm ^{2**}	16 mm ^{2**}	16 mm ^{2**}	16 mm ^{2**}	16 mm ^{2**}	16 mm ^{2**}
+Fuse	60 A	80 A	80 A	30 A	40 A	40 A

* = It is recommendable to use the sensor lines (terminals „Sense“, see option sensor lines).

Table 2: Setting of the battery size A or A+B, (capacity, Ah) by means of the switch „Cap.“:

Battery Capacity Selector Switch Cap.	Pb 1240		Pb 1250		Pb 1260		Pb 2420		Pb 2425		Pb 2430		Charging Phase I Safety Timer max. h
	Batt. Capacity Ah	Charging Current A	Batt. Capacity Ah	Charging Current A	Batt. Capacity Ah	Charging Current A	Batt. Capacity Ah	Charging Current A	Batt. Capacity Ah	Charging Current A	Batt. Capacity Ah	Charging Current A	
	75-92	33	88-110	40	120-150	50	40-48	17	46-57	20	58-72	25	5.2
	92-140	40	110-170	50	150-280	60	48-70	20	57-85	25	72-105	30	6.5
	140-250	40	170-310	50	280-440	60	70-125	20	85-160	25	105-190	30	9.5
	250-480	40	310-550	50	440-660	60	125-230	20	160-290	25	190-350	30	15

Note: If **two or more batteries** are connected to the charging ports A and B, set the **total capacity A+B** (total Ah-value of the connected units)!

This value should not exceed the max. "**Total Battery Capacity A or A+B**", which is mentioned in the technical data.

In case of high additional current consumption by connected consumers, the switch „Cap.“ can also be set by 1 step higher for compensation.

Due to the low current intensity, auxiliary port "C" must **not** be considered for calculation.

Table 3: Setting of the charging program for battery type (design) battery "A" (master)

Move the **2 slide switches "Type"** behind the front panel of the unit carefully to the desired position for **battery "A" (main battery, master)** using a small screw-driver. (Factory-adjusted position „Motor“= acid battery).











<p>Battery "A" „Type“ Selector Switch</p>	<p>If not being specified divergently by the battery manufacturer, the suitable charging program for the battery type (design, technology) can be determined by means of the following description and the technical data (voltage rates U1 and U2, nominal temperature and dwell times U1).</p> <p>Note: The possible parallel/floating operation with consumers being connected to the battery (batteries) is also automatically considered by all charging programs.</p>																								
	<p>„ Lead Acid “: Universal charging program for lead, acid/lead-acid batteries: For charging and trickle charge of supply (board) batteries. Ensures short charging times, high charging factor and acid mixing for open standard batteries and closed, low-maintenance, maintenance-free "non-solid electrolyte", "lead-acid", drive, lighting, solar and heavy duty batteries. Also suitable for recently developed batteries (low-antimonous, batteries with silver-alloy, calcium or similar) and batteries with low and very low water consumption, as well as AGM batteries with charging voltage indication "14.4 V".</p> <p>Universal Characteristic Line IU1oU2oU3:</p> <table border="0" data-bbox="309 900 1324 1025"> <tr> <td>U1</td> <td>Main/Full Charging:</td> <td>14.40 V</td> <td>(28.8 V)</td> <td>20 °C</td> <td>1.5-6 h</td> </tr> <tr> <td>U2</td> <td>Full/Trickle/Compensation Charging:</td> <td>13.50 V</td> <td>(27.0 V)</td> <td>20 °C</td> <td>24 h</td> </tr> <tr> <td>U3</td> <td>Storage Charging:</td> <td>13.05 V</td> <td>(26.1 V)</td> <td>20 °C</td> <td>Continuous</td> </tr> <tr> <td></td> <td>Regeneration 2 times a week</td> <td>14.40 V</td> <td>(28.8 V)</td> <td>20 °C</td> <td>1 h</td> </tr> </table>	U1	Main/Full Charging:	14.40 V	(28.8 V)	20 °C	1.5-6 h	U2	Full/Trickle/Compensation Charging:	13.50 V	(27.0 V)	20 °C	24 h	U3	Storage Charging:	13.05 V	(26.1 V)	20 °C	Continuous		Regeneration 2 times a week	14.40 V	(28.8 V)	20 °C	1 h
U1	Main/Full Charging:	14.40 V	(28.8 V)	20 °C	1.5-6 h																				
U2	Full/Trickle/Compensation Charging:	13.50 V	(27.0 V)	20 °C	24 h																				
U3	Storage Charging:	13.05 V	(26.1 V)	20 °C	Continuous																				
	Regeneration 2 times a week	14.40 V	(28.8 V)	20 °C	1 h																				
	<p>„ AGM “: Charging Program for Lead, AGM / Fleece Batteries VRLA-AGM Adapted to closed, gas-tight AGM (absorbed glass mat) batteries and batteries in lead-fleece technology requiring a particularly high level U1 for full charging.</p> <p>ATTENTION: It is highly recommended to check the specification sheet of the battery concerning the high charging voltage U1 14.7 V. Unsuitable batteries might age prematurely due to loss of electrolyte!</p> <p>Some manufacturers of AGM/fleece batteries are also prescribing a "Gel" or "Lead Acid" charging program for charging! In these cases, please set "Lead Acid" (14.3 V / 13.4 V).</p> <p>Characteristic Line AGM- / Fleece IU1oU2oU3:</p> <table border="0" data-bbox="309 1379 1324 1505"> <tr> <td>U1</td> <td>Main/Full Charging:</td> <td>14.70 V !!</td> <td>(29.4 V) !!</td> <td>20 °C</td> <td>1.5-6 h</td> </tr> <tr> <td>U2</td> <td>Full/Trickle/Compensation Charging:</td> <td>13.60 V</td> <td>(27.2 V)</td> <td>20 °C</td> <td>24 h</td> </tr> <tr> <td>U3</td> <td>Storage Charging:</td> <td>13.05 V</td> <td>(26.1 V)</td> <td>20 °C</td> <td>Continuous</td> </tr> <tr> <td></td> <td>Regeneration 2 times a week</td> <td>14.70 V</td> <td>(29.4 V)</td> <td>20 °C</td> <td>1 h</td> </tr> </table>	U1	Main/Full Charging:	14.70 V !!	(29.4 V) !!	20 °C	1.5-6 h	U2	Full/Trickle/Compensation Charging:	13.60 V	(27.2 V)	20 °C	24 h	U3	Storage Charging:	13.05 V	(26.1 V)	20 °C	Continuous		Regeneration 2 times a week	14.70 V	(29.4 V)	20 °C	1 h
U1	Main/Full Charging:	14.70 V !!	(29.4 V) !!	20 °C	1.5-6 h																				
U2	Full/Trickle/Compensation Charging:	13.60 V	(27.2 V)	20 °C	24 h																				
U3	Storage Charging:	13.05 V	(26.1 V)	20 °C	Continuous																				
	Regeneration 2 times a week	14.70 V	(29.4 V)	20 °C	1 h																				
	<p>„ Gel “: Charging Program for Lead Gel/Dryfit Batteries SLA: Adapted to closed, gas-tight Gel batteries with determined electrolytes, which are generally requiring a higher charging voltage level and longer dwell times U1 to achieve short charging times with particularly high capacity storage and to avoid total discharge, e. g. EXIDE, Sonnenschein dryfit- Start, Dryfit-Sport-Line, DETA Gel Battery Funline, Bosch AS Gel Batteries Va/Z, AS Gel Drive Batteries, AS Gel Lighting Batteries.</p> <p>If not being specified divergently by the battery manufacturer, also recommended for batteries in round cell technology, such as EXIDE MAXXIMA (DC).</p> <p>EXIDE, DETA, VARTA Characteristic Line Gel IU1oU2oU3:</p> <table border="0" data-bbox="309 1850 1324 1975"> <tr> <td>U1</td> <td>Main/Full Charging:</td> <td>14.40 V</td> <td>(28.8 V)</td> <td>20 °C</td> <td>4-10 h</td> </tr> <tr> <td>U2</td> <td>Full/Trickle/Compensation Charging:</td> <td>13.80 V</td> <td>(27.6 V)</td> <td>20 °C</td> <td>48 h</td> </tr> <tr> <td>U3</td> <td>Storage Charging:</td> <td>13.20 V</td> <td>(26.4 V)</td> <td>20 °C</td> <td>Continuous</td> </tr> <tr> <td></td> <td>Regeneration 2 times a week</td> <td>14.40 V</td> <td>(28.8 V)</td> <td>20 °C</td> <td>1 h</td> </tr> </table>	U1	Main/Full Charging:	14.40 V	(28.8 V)	20 °C	4-10 h	U2	Full/Trickle/Compensation Charging:	13.80 V	(27.6 V)	20 °C	48 h	U3	Storage Charging:	13.20 V	(26.4 V)	20 °C	Continuous		Regeneration 2 times a week	14.40 V	(28.8 V)	20 °C	1 h
U1	Main/Full Charging:	14.40 V	(28.8 V)	20 °C	4-10 h																				
U2	Full/Trickle/Compensation Charging:	13.80 V	(27.6 V)	20 °C	48 h																				
U3	Storage Charging:	13.20 V	(26.4 V)	20 °C	Continuous																				
	Regeneration 2 times a week	14.40 V	(28.8 V)	20 °C	1 h																				
	<p>Not used (operates like the "Gel" program)</p>																								

Table 4: Setting of the charging program for battery type "B" (design):

Move the **2 slide switches** behind the front panel of the unit carefully to the desired position for **battery "B"** using a small screw-driver. (Factory-adjusted position „B < A“ means "B" as starter battery).

<p>Battery „B“ „Type“ Selector Switch</p>	<p>If charging port "B" is used, 2 different operating modes are available for the <u>integrated charging current distributor</u> for battery "B".</p> <p>The total of the battery capacities (Ah) should not exceed the max. "total battery capacity A or A+B" being indicated in the technical data.</p> <p>Due to the low current intensity, auxiliary port "C" must not be considered for calculation.</p> <p>Non-utilization of charging port "B": If terminal "B" is not used, the total capacity range is at disposal for battery "A" (master). Move the switch to factory-adjustment „B < A“ (for starter battery).</p>												
	<p>"B = A" Battery Type "B" identical with battery "A": Battery "B" is of the same type (design Gel, AGM or Acid) as battery "A". Thus, it requires the same charging program as battery "A".</p> <p>Application: 2 separate battery banks in the industrial range or for boats.</p> <p>The charging current distributor charges both batteries with equal rights. Automatic charging begins with the battery showing the lower charging state ("A" or "B") with full charging current.</p> <p>If the charging state of both batteries is the same, the respective second battery will be included, both batteries ("A" and "B") will be charged fully at the same time, and the charge will be kept fully (trickle charge).</p> <p>The charging currents will be distributed automatically in the correct ratio. Consequently, battery "A" and "B" may have different capacity rates (Ah). In this case, the larger battery should be connected to charging port "A" (master).</p> <p>For reasons of safety, the warmer battery, A or B, will be considered for temperature compensation.</p> <p>Note: If required, the vehicle's starter battery is to be connected to the auxiliary port "C" (12 V (24 V) / 4 A.</p> <p>Characteristic line of charging for battery "B" = battery "A". (See table 3 and also temperature compensation.)</p>												
	<p>"B < A" Battery "B" is the starter battery (full charging current, also for the starter battery): Battery "B" is the starter battery of the vehicle. It is charged with an own fixed characteristic line for starter batteries (high starting capacity, low water consumption and maintenance expenditure).</p> <p>Application: <u>Intervention vehicles with high load of the starter battery</u> due to additional consumers.</p> <p>The charging current distributor automatically starts charging with full charging current of the battery showing the lower charging state ("A" or "B"), with which also <u>the starter battery</u> will be charged very quickly up to starting capacity, in case of need (in contrast to auxiliary port "C").</p> <p>After that, the respective second battery will be included and full charging of both batteries ("A" and "B") will be effected at the same time, whereas an own charging control (charging current, charging voltage, charging time) is active for the starter battery, and the charging currents are distributed in the correct ratio.</p> <p>This applies also to the trickle charge.</p> <p>The different capacity rates (Ah) are considered by the charger.</p> <p>Characteristic Line of Charging for Starter Battery "B": IU1oU2</p> <table border="0" data-bbox="311 1803 1356 1863"> <tr> <td>U1</td> <td>Main/Full Charging:</td> <td>14.1 – 14.4 V</td> <td>(28.2 - 28.8 V)</td> <td>20 °C</td> <td>2-3 h</td> </tr> <tr> <td>U2</td> <td>Full/Trickle/Storage Charging:</td> <td>13.2 – 13.5 V</td> <td>(26.8 - 27.1 V)</td> <td>20 °C</td> <td>Continuous</td> </tr> </table>	U1	Main/Full Charging:	14.1 – 14.4 V	(28.2 - 28.8 V)	20 °C	2-3 h	U2	Full/Trickle/Storage Charging:	13.2 – 13.5 V	(26.8 - 27.1 V)	20 °C	Continuous
U1	Main/Full Charging:	14.1 – 14.4 V	(28.2 - 28.8 V)	20 °C	2-3 h								
U2	Full/Trickle/Storage Charging:	13.2 – 13.5 V	(26.8 - 27.1 V)	20 °C	Continuous								
	<p>Function as „B < A“</p> 												
	<p>Function as „B < A“</p> 												

Connection Plan 12 V with 1 Battery:

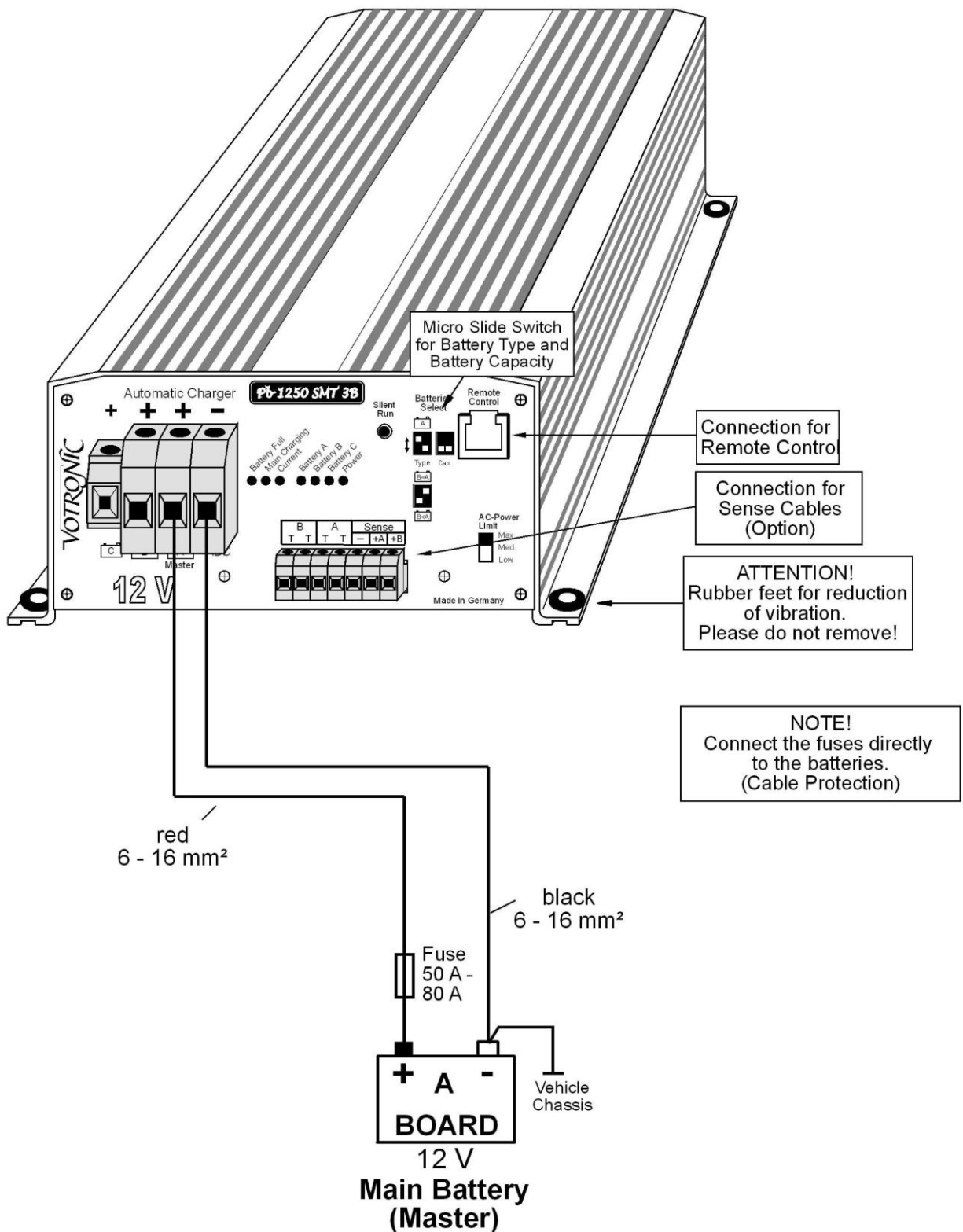

Note: If the unit is used with only 1 battery, use charging port A (master).



Safety Instructions: Connection is only allowed to a shock-proof socket, which has been installed according to the valid technical regulations, protected with max. 16 A (if required mobile/stationary with a fault current breaker (FI) with a nominal residual current of 30 mA).

Connection Plan 24 V with 2 Main Batteries, Sensor (Sense) Lines and Temperature Sensors:

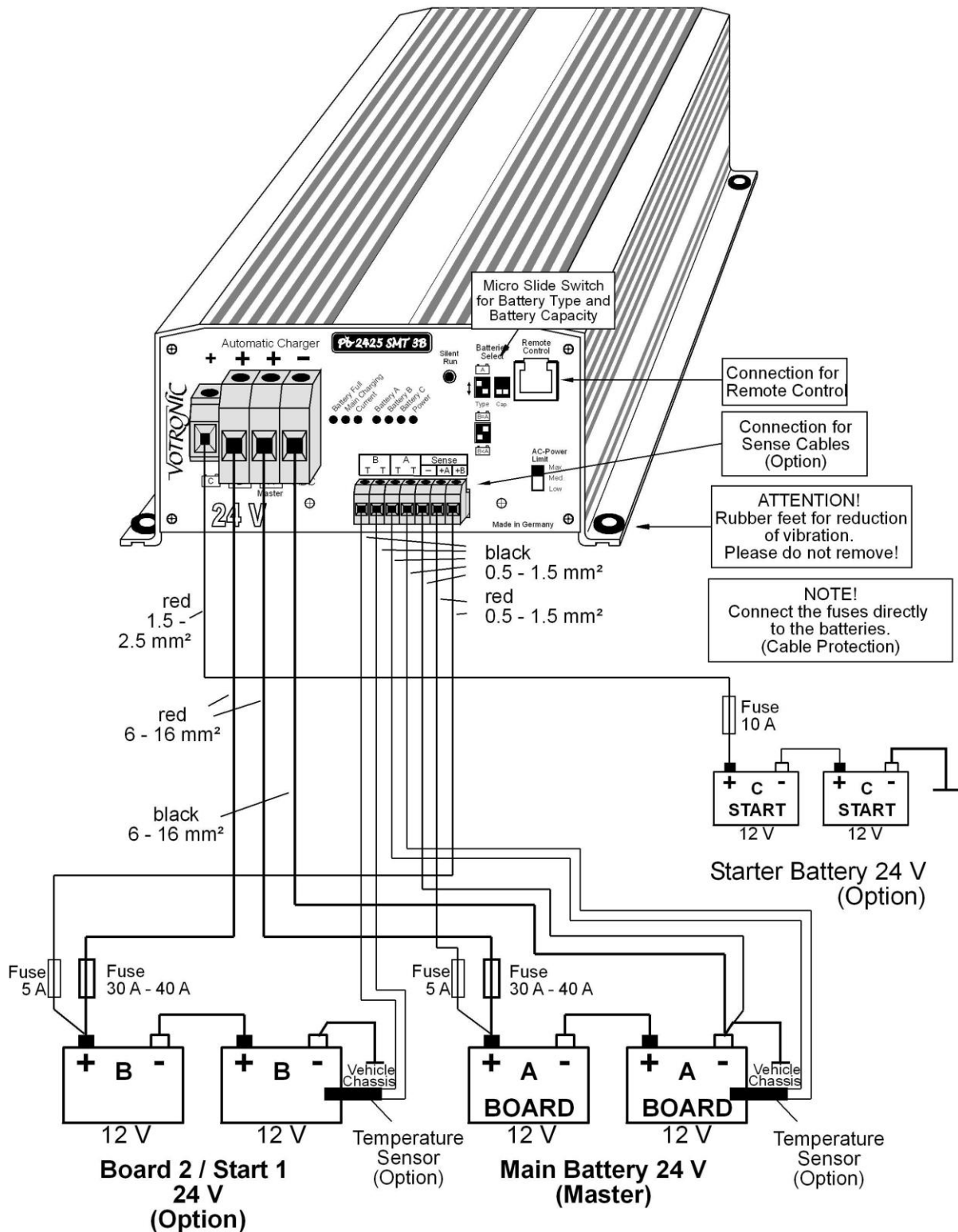

Note: If the unit is used with only 1 battery 24 V, use charging port A (master).



Safety Instructions: Connection is only allowed to a shock-proof socket, which has been installed according to the valid technical regulations, protected with max. 16 A (if required mobile/stationary with a fault current breaker (FI) with a nominal residual current of 30 mA).

Main Charging Port "Battery A" (Master):

Charging port with full charging current, set charging program according to table 3.

Note: If the unit is used with only 1 battery, use this charging port A (master).

Further Switching Types and Options:

Temperature Sensors (Terminals „T T“ Battery A and B):

Required Accessories: 1 or 2 Pieces Temperature Sensor, Order No. 2001

The temperature sensor controls the **battery temperature** and the temperature-dependent correction of the charging voltage. (Characteristic lines, see also "**Temperature Compensation**" in this manual).

Connect the sensor to the corresponding terminals „T T“ of the unit (any polarity).

Do not mix up the batteries (A, B) (see connection plan)!

Sensor Installation:

The **thermal contact** of sensor and **battery** (inside temperature) **should be well**. Thus, it should be screwed down to the negative pole of the battery. It is also possible to fasten it at the sidewall centre of the battery casing. Ensure that the installation place is not influenced by any source of heat (motor unit, exhaust, heater etc.).

Temperature Compensation:

The temperature-dependent charging voltage of the battery will be adapted automatically to the battery temperature.

The temperature sensor measures the battery temperature. In case of low temperatures (winter operation), the charging voltage will be increased in order to improve and accelerate full charging of the weak battery. Sensitive consumers are protected by a limitation of the voltage in case of very low outside temperatures.

In case of summery temperatures, the charging voltage is reduced to minimize the load (gassing) of the battery and to extend the lifetime of gas-tight batteries.

Battery Protection (also refer to Characteristic Lines "Charging Voltage Rates and Temperature Compensation"):

In case of high battery temperatures (depending on type: 54 °C or 58 °C), the charging current will be reduced to 50 % for reasons of safety. If the battery temperature still continues to rise, a complete disconnection will be effected by the safety relays, as soon as the temperature is exceeded by some °C, the LED „**Main Charging**“ will be **flashing**, but any charging data being recorded hitherto will be kept in memory. Automatic charging will be resumed as soon as the temperature drops below the above mentioned temperature values. The charging cycle will also be blocked, if the battery temperatures drop below -40 °C.



The charger recognizes automatically a missing sensor, cable break or short-circuit of the sensor lines, as well as unreasonable measuring values. In that case, it will switch to the usual charging voltage rates of 20 °C to 25 °C being recommended by the battery manufacturers.

If 2 temperature sensors are connected, the battery being warmer (A or B) will be automatically considered for reasons of safety.

Option: 2. (Main) Charging Port „Battery B“

Charging port with full charging current, use and setting of the charging program according to table 4.

Option: 3. (Auxiliary) Charging Port "Battery C" 12 V/4 A (24 V/4 A)

Charging port with inferior charging current: That charging port is provided for support charging and trickle charge of the **vehicles' starter battery** in case of extended stop periods and for compensation of the charge for e. g. short-term consumers (interior lighting of the driver's cabin etc.), if the starter battery had not been connected to port "B". Port C is active together with the main charging port A. The functioning during the charging mode can be recognised by an increasing voltage of the starter battery.

The output voltage of the third port is slightly lower than the output voltage of the main ports, and its current intensity and voltage is limited in such a way, that overcharging of the vehicle's starter battery can be excluded.



The auxiliary charging port of battery C may be used or not used, the function of the main charging ports of battery A and B will not be affected, except that the current rate is reduced by the inferior current rate of battery C.

The port can also be switched by an external relay (see connection plan) to serve as signalling port for a vehicle motor locking (preventing a motor start if the power supply of the vehicle is still inserted).

Note: The port supplies voltage during proper charging mode.

The port is disconnected in case of power failure, switched-off mains switch or if battery or unit failures had been recognized.

Option: Sensor Lines (Terminals „Sense -, +A, +B“)

In case of powerful chargers being equipped with long charging cables, it is recommendable to measure the battery voltage via "sensor lines" directly at the battery. This allows a more precise observation of the charging voltage rates. It is recommendable to install these sensor lines in case of charging cables, which are strongly deviating from the values in table 1.

Please observe for 24 V operation, that the „Sense“ line should be connected to the „+“ pole of that battery, where also the „+“ charging cable of the charger will be connected.

Never mix up batteries A and B! Absolutely observe the connection plan!

If several batteries are connected in parallel as battery system (battery bank) to A or B, the „Sense“ line can be connected to one of the + poles being connected to each other.



The charger will automatically recognize and evaluate the sensor line(s).

If the sensor line is not installed or in case of a cable break or fuse failures, it will be switched to normal operation with charging cable compensation (calculated compensation of the voltage losses on the charging cables).

Option: Remote Control (Tip Jack „Remote Control“)

If the charger has been installed at a difficultly accessible location, the **Remote Control S for Automatic Charger (Order No. 2075)** can be used for remote control of the charging process (plug-and-go connection cable of 5 m length is included in the delivery scope).

Connection:

Just insert the plug of the remote control into the tip jack "Remote Control" of the charger.

Function:

The remote control is equipped with the same pilot lamps (light-emitting diodes) as the charger.

Switch Function (also refer to paragraph Key „Silent Run“):

Position „ON“: Charger works with full charging capacity.

Position „OFF“: Ensures silent operation on board by means of the function "silent run", see below.



Key „Silent Run“, noise optimised operation (night operation):

Press the key for a short moment for activation:

- The internal cooling fan of the unit will be set to constant low noise, steady speed.
- All light-emitting diodes will be switched off, only the current display „Current“ will still be lighting weakly.
- Of course, all charging and control functions continue working internally to the full extent
- The reduced cooling capacity might reduce the charging capacity to approx. 80 %, depending on the ambient temperature of the charger.

Manual reactivation of the display and thus of the full charging capacity:

- is possible at any time by pressing the key again
- Automatic reactivation after 10 hours by integrated timer (end of nighttimes).

Mains Switch (Unit Rear):

The charger is to be switched off prior to connection of the batteries or other connection tasks (switch position „0,“)! If being switched-off for a short time, a restart of a complete charging cycle for the battery (batteries) is possible. It is a "real" mains switch. In switch position "0" the unit does not consume any (stand-by) capacity.

Switch „AC Power Limit“:

This switch allows reducing the capacity of the charger to be able to use it also, if the local 230 V mains only offers smaller capacity rates (weak protection of the parking lot, country current supply or Marina, generator operation).

The reduced current consumption of the unit from the mains supply in case of switch position „Med.“ or „Low“ can be drawn from the technical data below „Delimitation of Capacity / Switch „AC Power Limit“.

Normal operation with maximum input power and charging capacity is realised by switch position "Max".

Further actions or maintenance of the unit are not required.

Pilot Lamps:

„Battery Full“ (Battery (Batteries) fully charged, **green**):

- If it is lighting: Battery (batteries) has (have) been charged to 100 %, trickle charge U2, finished.
- If it is flashing: Main charging process is effected in the charging phase U1, indication of charging state of approx. 80 % (short flashing), gradual increase to 100 % (long flashing).
- Off: Main charging process is still being executed in the phase I.

„Main Charging“ (Main charging, **yellow**):

- If it is lighting: Main charging process is effected in the phase I or the charging phase U1.
- Off: Trickle charge U2.
- If it is flashing: 1) Disconnection of the battery protection: Temperature of battery A or battery B < -40 °C or overtemperature, (depending on the type: 57 °C or 63 °C), automatic reset after slight cooling down, or
2) External overvoltage battery A, B or C, > 15.50 V (> 31.0 V), Automatic reset at <12.75 V (< 25.5 V)

„Current“ (Charging Current, **red**):

- The lighting intensity of the LED „Current“ (Charging Current) will be **reduced or increased depending on the supplied charging current**.

„Battery A“ (yellow):

- If it is lighting: Control and charging of main battery „A“ (Master).
- Off: Charging port is blocked (safety switch)

„Battery B“ (yellow):

- If it is lighting: Control and charging of main battery „B“.
- Off: Charging port is blocked (safety switch)

„Battery C“ (yellow):

- If it is lighting: Control and charging of auxiliary battery „C“.
- Off: Charging port is blocked (safety switch)

„Power “ (Mains, **red**):

- If it is lighting: Mains supply is available and charger is ready for operation.
- If it is flashing: 1. Disconnection of safety timer, duration of the charging phase I was too long, too many consumers, Battery defective (short-circuit of the cells). Reset by setting mains switch to position "0".
2. Internal unit failure (overheating), automatic reset after cooling down.
3. Reverse battery (+ and - are mixed up).

Charging Process Main Port Battery „A“ (Master):

A new, complete main charging cycle will be executed:

- After a power failure or disconnection by means of the mains switch (position „O“).
 - In case of a lower deviation of the battery reset voltage of 12,75 V (25,50 V) beyond the maximum charger current for 30 seconds due to high load.
1. Charging aid for totally discharged battery. From 0 V, it will be subject to gentle preliminary charging with a small current rate up to 8 V (16 V).
 2. Maximum charging current (**I-Phase**) in the average voltage range from 8 V (16 V) to the beginning of the phase U1 for **short charging times**. The LED „Main Charging“ is lighting, and 75 -80 % of the capacity will be charged. The duration of phase I depends on the battery conditions, the load by the consumers and the charging state. The charger records the charging process and switches automatically to the phase U1. For reasons of safety, the phase I will be terminated by the safety timer after 15 hours, at the latest (cell defects etc.).
 3. During the **Phase U1** (LED „Main Charging“ is lighting) the battery voltage will be kept constantly on a high level. The green LED „Battery Full“ is flashing, and the additional high battery capacity will be charged. The battery charging current is decreased slowly while full charging is increasing. The charger controls the charging time as well as the charging current. From these values and from the course of charging being recorded during the phase I, the charger determines the **100 % full charge point** of the battery for automatic commutation to U2. In contrast to conventional chargers with fixed default values for commutation of the charging current, an unnecessary long phase U1 is avoided, which might be caused by consumer load falsifying the charging current. The LED „Main Charging“ will stop lighting.
 4. **Phase U2** (LED „Battery Full“ is lighting permanently): The charger has now switched to the lower voltage for trickle charge maintaining 100 % charge of the battery. Only the low compensating recharging current is flowing, which is determined by the battery, and which is required for constant conservation of the full charge.
Charging program acid / lead-acid battery (lead acid): The charging voltage U2 is limited in time to ensure gentle recharging, and the compensation charging of the cells with small charging current rates is a little increased. After that, it will be switched to the third, lower voltage rate U3 for constant conservation of the full charge.
 5. **Battery Regeneration**: To ensure a circulation of acid accumulation in case of extended periods of trickle charge (due to e. g. stop periods of the vehicle), the charging voltage rate will be raised automatically to U1 twice a week for one hour. After that, it will be returned directly to U2 (U3).

Note: During the phases U1, U2 (U3) (Battery Full) almost the total **charger current** is available for additional supply of consumers without any discharge of the battery.

Charging Process Main Port Battery „A“ (Master):

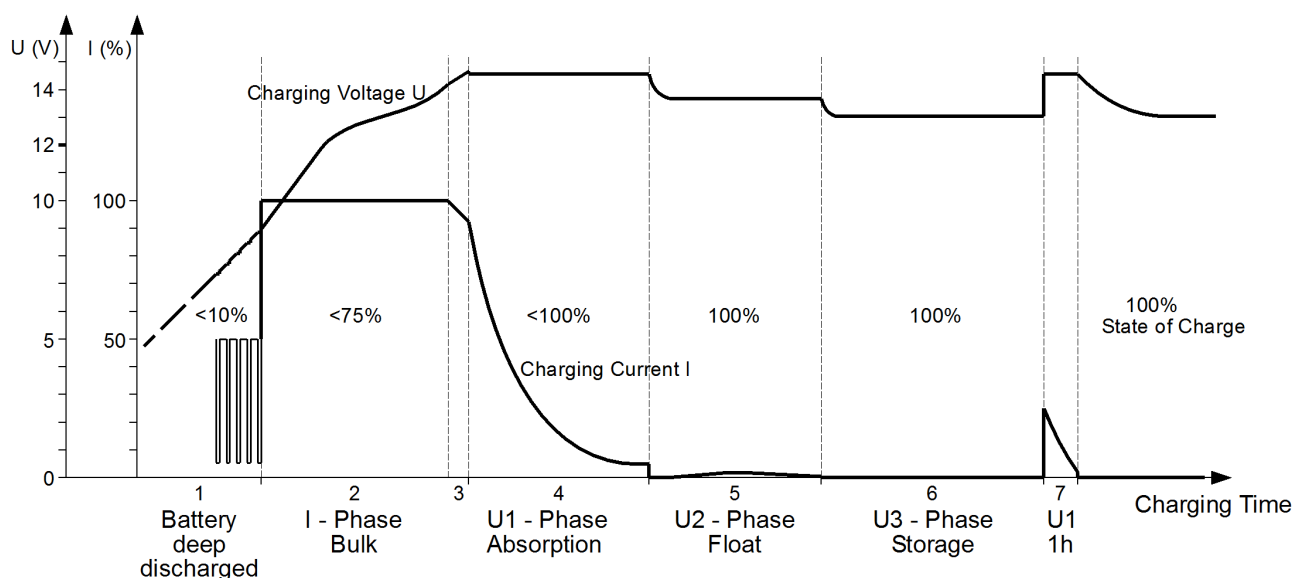

Charging Voltage Rates of Battery „A“ (Master) and Temperature Compensation (Switch „Type“):

(In case of 24 V operation: Multiply all indicated voltage rates by 2! TS = Temperature Sensor)

Charging Program „Gel“, IU1oU2oU3

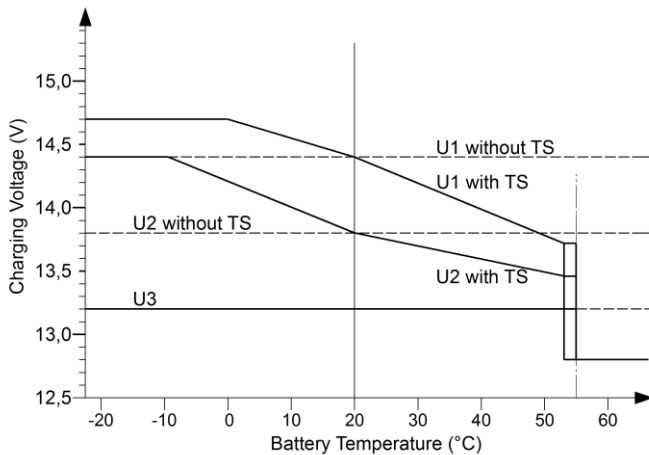

Charging Program „AGM / Fleece“, IU1oU2oU3

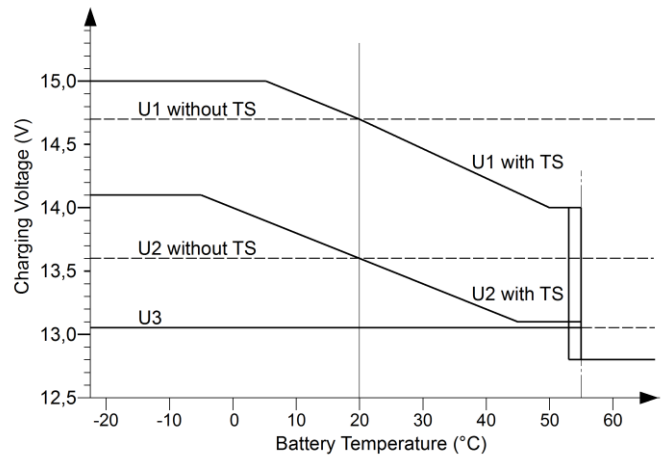

Charging Program „Lead Acid“, IU1oU2oU3

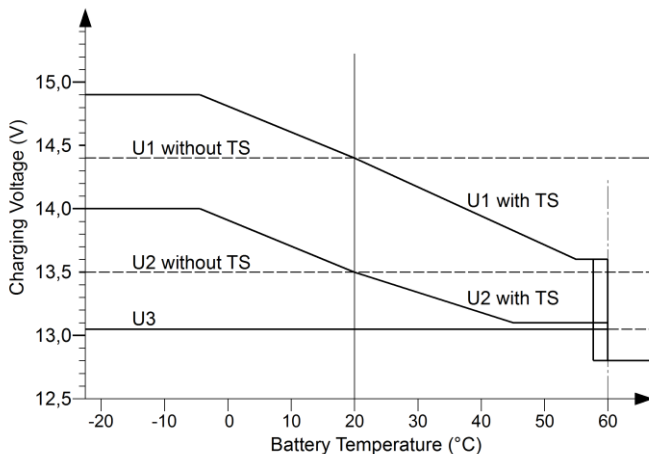

Operating Instructions:

- Overvoltage Protection:**
 The charger protects itself against connection of excessive battery voltage rates or will be switched-off in case of defective additional charging systems (solar systems, generators or similar systems), switching threshold 15.5 V (31.0 V), delay 20 s.
- Overvoltage Limitation:**
 Charging voltage limitation to max. 15.0 V (30.0 V) during all charging modes to protect sensitive consumers.
- Overload / Overheating Protection Charger:**
 The charger is equipped with a double electronic protection against overload and with an automatic protection against adverse installation conditions (e. g. insufficient ventilation, excessive ambient temperatures) by gradual reduction of the charging capacity.

Several batteries (battery bank) at one charging port (A and/or B):

According to the battery manufacturer, **permanent** parallel operation is admissible in case of two or several batteries of the same voltage, type, capacity, as well as of the same age (history) in cross connection.

The total capacity (Total Ah) should not exceed the indicated maximum battery capacity, and it is to be set correspondingly using the selector switch „Cap.“!

The batteries are to be „paralleled“, i. e. the „+“ connections of the batteries are to be coupled, and they are to be connected to the „+“ connection of the charger.

The minus (-) connections have to be coupled in the same way.

Technical Data:

**Pb 1240
SMT 3B**

**Pb 1250
SMT 3B**

**Pb 1260
SMT 3B**

	Pb 1240 SMT 3B	Pb 1250 SMT 3B	Pb 1260 SMT 3B
Nominal Operating Voltage (AC):	230 V / 45 – 65 Hz		
Operating Voltage Range (AC):	190 V – 265 V (Full Charging Capacity), Short-time (5s) 300 V		
Derating of the charging rate to approx. 50 % at 110 V AC:	Yes	Yes	Yes
Sinusoidal Power Factor Correction (CosPhi = 1):	Yes	Yes	Yes
Max. Power Consumption (AC):	680 W	840 W	1020 W
Max. Power Consumption (230 V AC):	3.0 A	3.7 A	4.4 A
Switch "AC Power Limit" Delimitation of Capacity (207 V AC):			
Position „Max.“ (Maximum Charging Capacity):	3.3 A / 680 W	4.1 A / 840 W	4.9 A / 1020 W
Position „Med“ (Reduced Mains and Charging Capacity):	1.9 A / 390 W	1.9 A / 390 W	2.4 A / 500 W
Position „Low“ (Reduced Mains and Charging Capacity):	1.4 A / 280 W	1.4 A / 280 W	1.9 A / 390 W
Charging Ports Batteries "A" and "B":			
Battery Voltage (A / B):	12 V / 12 V	12 V / 12 V	12 V / 12 V
Battery Capacity adjustable (A or A+B total):	75 Ah-480 Ah	88 Ah-550 Ah	120 Ah-660 Ah
Charging Current Phase I (A, B or A+B) max.:	40 A	50 A	60 A
Charg./Floating/Load Curr., contr., Phase U1-,U2(3):	0 A - 40 A	0 A -50 A	0 A -60 A
Automatic Charging Current Distributor Batt. A/B:	Yes	Yes	Yes
Min. Battery Voltage for Charging Start:	0 V	0 V	0 V
Preliminary Charging Current, Totally Discharged Battery 0V-8V:	20 A	25 A	30 A
Reverse Current from Battery (Power Failure):	<0.2 mA	<0.2 mA	<0.2 mA
Reset Voltage (30 sec):	12.75 V	12.75 V	12.75 V
Limit of Charging Voltage (Consumer Protection):	15.00 V	15.00 V	15.00 V
External Overvoltage Disconnection (20 sec.):	15.50 V	15.50 V	15.50 V
Ripple Factor Voltage:	< 50 mV rms	< 50 mV rms	< 50 mV rms
Charging Timer:	3-fold	3-fold	3-fold
Safety protection against reverse battery/ short-circuit/back discharge:	Yes / Yes	Yes / Yes	Yes / Yes
Safety Timer per Charging Phase I- /U1-/ (U2-):	Yes / Yes	Yes / Yes	Yes / Yes
Input for Battery Temperature Sensor A / B:	Yes / Yes	Yes / Yes	Yes / Yes
Input for Battery (+) Sensor Line A / B:	Yes / Yes	Yes / Yes	Yes / Yes
Autom. Battery Regeneration: 2 x week 1 h:	Yes / Yes	Yes / Yes	Yes / Yes
Charging Port Battery "A" (Master):			
Adjust. Charact. Lines of Charg. Gel, AGM, Lead-acid:	Yes	Yes	Yes
Charging/Floating/Load Current, controlled Phase IU1oU2(3):	0 A - 40 A	0 A -50 A	0 A -60 A
Power Pack Operation (e. g. continued supply during battery replacement):	Yes	Yes	Yes
Charging Port Battery „B“:			
Charact. Lines of Charg. as Batt. "A" Gel, AGM, Lead-acid:	Yes	Yes	Yes
or characteristic line fixed for vehicle's starter battery:	Yes	Yes	Yes
Charging/Floating/Load Current, controlled Phase IU1oU2(3):	0 A - 40 A	0 A -50 A	0 A -60 A
Auxiliary Port Starter Battery "C":			
Nominal Voltage of Battery (fixed for vehicle's starter battery):	12 V / 0 – 4 A	12 V / 0 – 4 A	12 V / 0 – 4 A
Protection against overcharge, reverse battery, overload, short-circuit:	Yes	Yes	Yes
Fitting Position of Unit:	any	any	any
Temperature Range:	-20 / +45 °C	-20 / +45 °C	-20 / +45 °C
Speed-controlled, temperature-controlled Fan:	Yes	Yes	Yes
Gradual Reduction of Charging Capacity in Case of Overtemperature:	Yes	Yes	Yes
Safety Disconnection in Case of Overheating:	Yes	Yes	Yes
Noise-reduction of Fan, Night Operation (Silent Run):	Yes	Yes	Yes
Port Remote Control Automatic Charger:	Yes	Yes	Yes
Protection Class/System of Protection:	I / IP21	I / IP21	I / IP21
Dimensions, incl. mounting flanges (W/H/D, mm):	310x138x72	310x138x72	310x138x72
Weight:	2400 g	2400 g	2450 g
Ambient Conditions, Humidity of Air:	max. 95 % RH, no condensation		
Safety Regulations:	EN 60335-2-29		

Technical Data:

	Pb 2420 SMT 3B	Pb 2425 SMT 3B	Pb 2430 SMT 3B
Nominal Operating Voltage (AC):	230 V / 45 – 65 Hz		
Operating Voltage Range (AC):	190 V – 265 V (Full Charging Capacity), Short-time (5s) 300 V		
Derating of the charging rate to approx. 50 % at 110 V AC:	Yes	Yes	Yes
Sinusoidal Power Factor Correction (CosPhi = 1):	Yes	Yes	Yes
Max. Power Consumption (AC):	660 W	830 W	1000 W
Max. Power Consumption (230 V AC):	2.9 A	3.6 A	4.3 A
Switch "AC Power Limit" Delimitation of Capacity (207 V AC):			
Position „Max.“ (Maximum Charging Capacity):	3.2 A / 660 W	4.0 A / 830 W	4.8 A / 1000 W
Position „Med“ (Reduced Mains and Charging Capacity):	1.9 A / 390 W	1.9 A / 390 W	2.4 A / 500 W
Position „Low“ (Reduced Mains and Charging Capacity):	1.4 A / 280 W	1.4 A / 280 W	1.9 A / 390 W
Charging Ports Batteries "A" and "B":			
Battery Voltage (A / B):	24 V / 24 V	24 V / 24 V	24 V / 24 V
Battery Capacity adjustable (A or A+B total):	40 Ah-230 Ah	46 Ah-290 Ah	58 Ah-350 Ah
Charging Current Phase I (A, B or A+B) max.:	20 A	25 A	30 A
Charg./Floating/Load Curr., contr., Phase U1-,U2(3):	0 A -20 A	0 A -25 A	0 A -30 A
Automatic Charging Current Distributor Batt. A/B:	Yes	Yes	Yes
Min. Battery Voltage for Charging Start:	0 V	0 V	0 V
Preliminary Charging Current, Totally Discharged Battery 0 V-16 V:	10 A	12 A	15 A
Reverse Current from Battery (Power Failure):	<0.4 mA	<0.4 mA	<0.4 mA
Reset Voltage (30 sec):	25.50 V	25.50 V	25.50 V
Limit of Charging Voltage (Consumer Protection):	30.00 V	30.00 V	30.00 V
External Overvoltage Disconnection (20 sec.):	31.00 V	31.00 V	31.00 V
Ripple Factor Voltage:	< 80 mV rms	< 80 mV rms	< 80 mV rms
Charging Timer:	3-fold	3-fold	3-fold
Safety protection against reverse battery/ short-circuit/back discharge:	Yes / Yes	Yes / Yes	Yes / Yes
Safety Timer per Charging Phase I- /U1- / (U2-):	Yes / Yes	Yes / Yes	Yes / Yes
Input for Battery Temperature Sensor A / B:	Yes / Yes	Yes / Yes	Yes / Yes
Input for Battery (+) Sensor Line A / B:	Yes / Yes	Yes / Yes	Yes / Yes
Autom. Battery Regeneration: 2 x week 1 h:	Yes / Yes	Yes / Yes	Yes / Yes
Charging Port Battery "A" (Master):			
Adjust. Charact. Lines of Charg. Gel, AGM, Lead-acid:	Yes	Yes	Yes
Charging/Floating/Load Current, controlled Phase IU1oU2(3):	0 A -20 A	0 A -25 A	0 A -30 A
Power Pack Operation (e. g. continued supply during battery replacement):	Yes	Yes	Yes
Charging Port Battery „B“:			
Charact. Lines of Charg. as Batt. "A" Gel, AGM, Lead-acid: or characteristic line fixed for vehicle's starter battery:	Yes	Yes	Yes
Charging/Floating/Load Current, controlled Phase IU1oU2(3):	0 A -20 A	0 A -25 A	0 A -30 A
Auxiliary Port Starter Battery "C":			
Nominal Voltage of Battery (fixed for vehicle's starter battery):	24 V / 0 – 4 A	24 V / 0 – 4 A	24 V / 0 – 4 A
Protection against overcharge, reverse battery, overload, short-circuit:	Yes	Yes	Yes
Fitting Position of Unit:	any	any	any
Temperature Range:	-20 / +45 °C	-20 / +45 °C	-20 / +45 °C
Speed-controlled, temperature-controlled Fan:	Yes	Yes	Yes
Gradual Reduction of Charging Capacity in Case of Overtemperature:	Yes	Yes	Yes
Safety Disconnection in Case of Overheating:	Yes	Yes	Yes
Noise-reduction of Fan, Night Operation (Silent Run):	Yes	Yes	Yes
Port Remote Control Automatic Charger:	Yes	Yes	Yes
Protection Class/System of Protection:	I / IP21	I / IP21	I / IP21
Dimensions, incl. mounting flanges (W/H/D, mm):	310x138x72	310x138x72	310x138x72
Weight:	2400 g	2400 g	2450 g
Ambient Conditions, Humidity of Air:	max. 95 % RH, no condensation		
Safety Regulations:	EN 60335-2-29		

Option: Remote Indicator IP67

Order No. 2081, plug-and-go connection cable, 5 m length, included in the delivery scope.

The green light-emitting diode indicates the readiness for operation of the charger and the mains power supply.

The remote indicator can be installed at any desired location via a bore hole, 8 mm. It can be installed at a well visible location in the inside area (for instance in the dash board), as well as outside, such as near the driver's door. The delivered packing washer allows front installation with high tightness IP67.

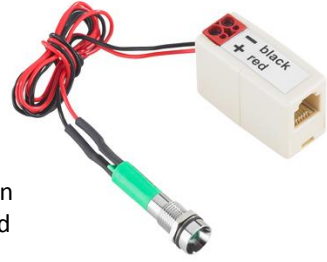

Connection:

Just insert the plug of the remote control into the tip jack "Remote Control" of the charger.



Declaration of Conformity:

According to the stipulations of the regulations 2006/95/EG, 2004/108/EG, 95/54/EG this product corresponds to the following standards or standardized documents:

EN60335-2-29; EN55014; EN55022 B; DIN14685; DIN40839-1; EN61000-3-2; EN61000-3-3; EN61000-4-2; EN61000-4-3; EN61000-4-4; EN61000-4-5; EN61000-4-6; EN61000-4-11



Disposal of the product in the normal household waste is not allowed.



with the directives for Reduction of Hazardous Substances in Electrical and Electronic Equipment.

The product conforms to RoHS. Thus, it complies



Delivery Scope:

- Charger
- Mains Supply Cable with IEC Power Plug
- Operating Manual

Temperature Sensor



Available Accessories: Temperature Sensor (1 or 2 pieces can be connected)
 Remote Control S for Automatic Charger
 Remote Indicator IP67
 Battery Status Display IP67

Order No. 2001
 Order No. 2075
 Order No. 2081
 Order No. 2082

Subject to misprints, errors and technical modification without notice.

All rights reserved, particularly the right of reproduction. Copyright © VOTRONIC 03/16.

Made in Germany by VOTRONIC Electronic-Systeme GmbH & Co. KG, Johann-Friedrich-Diehm-Str. 10, 36341 LAUTERBACH/GERMANY
 Phone: +49 (0)6641 / 91173-0 Fax: +49 (0)6641 / 91173-20 E-mail: info@votronic.de Internet: www.votronic.de