

Semi-flexible solar modules FLPRO series

INSTALLATION INSTRUCTIONS

I. GENERAL INFORMATION

Thank you for purchasing this Photonic Universe product. Our photovoltaic modules are built using innovative technology and superior quality materials.

The following guidelines apply exclusively to FLPRO series modules (including FLPROJBB series) only. Please read the following instructions carefully and pay attention to all safety recommendations.

Warning! Any work on solar modules including wiring should follow general safety standards, alongside these installation instructions. Works should always be carried out by an appropriately qualified person. Photonic Universe Ltd is not responsible for any problems arising from inappropriate installation or use of the product.

In addition to these installation instructions, we recommend following the guidelines of IEC/TS 62548.

Photonic Universe Ltd reserves the right to modify its products, technical specifications and these installation instructions without prior notice.

ELECTRIC SHOCK WARNING

This product generates electrical current when the front side is exposed to light.

Even if voltage and current from a single module is low, touching the terminals or wiring may cause an electric shock or burns. These risks increase when many modules are installed together – generating higher voltages and currents which are dangerous and could be lethal. Photonic Universe Ltd will not be held responsible in any way for accidents, damage and injury, including electric shock, caused by incorrect use or installation.

To avoid any risk, turn the front side of the module away from the sun or any intense source of light when wiring (alternatively cover the front side during the installation).

- Do not use different types or models of solar modules in the same system.
- Do not modify the electrical connections of the modules, in particular do not open or remove the junction box.
- Do not cut or pierce the module, this may cause live components to be exposed and/or damage the module.
- Do not bend or apply excessive force to the cables.
- Installation, maintenance and removal of photovoltaic modules must take place on dry surfaces.
- Use tools with insulated grips only.
- Do not use photovoltaic modules near flammable or explosive substances.
- Keep the modules in their original packaging until the moment of their installation.
- Do not use damaged photovoltaic modules (damaged during transport or installation).
- Do not apply any protections, paint or varnish to the modules.
- Do not drop heavy or sharp items onto the modules.
- Do not concentrate sunlight (e.g. mirrors or lenses) or other sources of artificial light on the modules.
- Do not dismantle or remove any part or label affixed by the manufacturer.
- Do not install modules in locations where they may be submerged in water for lengthy periods.

II. HANDLING

Although this product has been designed to be robust, it must be handled with care:

- Do NOT bend or kink the module unnecessarily (note: the modules are semi-flexible but should only be curved when mounted).
- Do NOT put the module on its corners.
- Do NOT apply excessive force to the module (e.g. do not throw the module).
- Do NOT puncture the module.
- Do NOT step on the module.
- Do NOT lean the module on sharp or spiky objects.
- Do NOT use the junction box or the connection cable as a handle.
- Do NOT stack the modules without packaging (the sharp edges of the junction box might damage the front surface of another module).
- Store the modules securely in a cool and dry place. The packaging is not weather-proof.

The module may be handled by the edge, but only if it is held vertically and without excessive pressure to the edges of the cells. The modules should not be held by the short ends or corners as this may cause excessive bending under their own weight.

Follow the above handling requirements to ensure that PV cells inside the module do not break, and no damage is caused to the protective layer of the composite material.

MAXIMUM BENDING

Photonic Universe modules of FLPRO series are semi-flexible, but they cannot be rolled-up or folded. The maximum curvature allowed is up to the minimum bending

radius 2000 mm. The modules should only be bent **lengthwise**. Do not bend the modules widthwise.

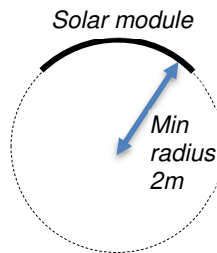

In practice the requirement to have a minimum bending radius 2m translates into the requirement to have a certain maximum height of the arch when measured against a straight horizontal line.



The maximum height of the arch of a bent solar module will depend on the length of the module. The table below provides some examples.

Length of the module	Maximum height of the arch
50 cm	16 mm
80 cm	40 mm
100 cm	62 mm
120 cm	89 mm
140 cm	121 mm
150 cm	139 mm
170 cm	178 mm
200 cm	245 mm

Excessive or multiple bending must be avoided when handling the modules. The minimum bending radius, mentioned above, is only for the purpose of mounting permanently on a curved surface. The modules are not designed to withstand such maximum bending radius for applications where this bending occurs periodically.

Important! The curvature of the module **must be distributed uniformly** across the entire length of the module. Sharp bending may cause permanent damage to the solar cells.

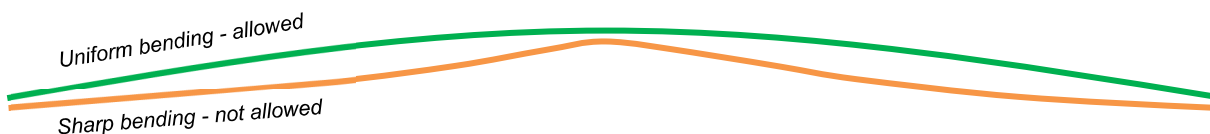

STEPPING ON MODULES

In order to maximise the service lifetime, **do not step on modules**. Depending on the strength of surface underneath, stepping on modules might eventually damage them.

If modules are installed in areas accessible by people who might not be aware of this requirement, use weather-resistant stickers to warn them that the modules should not be stepped on. An example of such sticker is provided below.



III. MECHANICAL INSTALLATION

While installing the modules, the installer must always follow general rules for safety at work, rules for electrical installation and devices, construction rules and all other regional and national rules and regulations.

Modules can be installed in a landscape or portrait orientation, and fixed in place by gluing, screwing or riveting.

Warning! Do not modify or damage the backsheet of the module in any way.

GLUING

If your module does not come with an adhesive layer, the module can be mounted to the surface by using an appropriate sealant / adhesive or double-sided tape. If adhesive is used, make sure it is suitable for outdoor applications (with a wide temperature range, UV protection etc).

The surfaces onto which the modules are to be glued must be very clean and dry. The installation must be carried out carefully and with precision, as this permanent method does not allow repositioning. The installation surface has to be smooth and must allow for good bonding with the chosen adhesive.

When mounting with a sealant / adhesive, you should not start using the module until the adhesive is dry (typically 24h).

Before the permanent installation we recommend checking performance of the module by measuring the open circuit voltage (V_{oc}) and short circuit current (I_{sc}) in bright direct sunlight with no obstructions, and comparing to the specifications. To achieve readings close to specifications, the sun should be high in the clear sky, and the module should be facing the sun directly.

If your module comes with the double-sided adhesive layer, make sure your chosen surface area can form a good bond with the adhesive (for example do not attempt to attach the module to canvas or anti-slippery rough paint because such bond is unlikely to be strong).

Warning! For most smooth hard surfaces, double-sided adhesive tape of the module makes a very strong immediate bond and does not allow repositioning. Trying to remove the module, even if it is only partially attached, can seriously damage the solar cells.

In order to glue the module with the double-sided adhesive tape, follow the steps below:

1. Recommended application temperature for gluing is 18°C to 35°C. Make sure all materials have roughly the same temperature prior to bonding.
2. The installation surface must be free from dust, grease and oil. If required, clean the surface with a degreasing agent. Loose paint or protective coatings must be removed or stabilized.
3. Lift the module and remove the protective film from the back, exposing a sticky surface. Do not allow contact with skin.
4. Attach the module to the surface. It is recommended to use two people, and a hand-roller in order to evenly spread the compacting pressure.
5. Note: to achieve full adhesive strength, leave at least 24 hours at normal temperature.

Avoid any unnecessary loads. Bonds must be made in such a way that no lever action (cleavage stress) can arise. Any shearing or tensile stress should spread across the entire adhesive surface. Continuous peeling stresses reduce the quality of the bond.

If your module comes with the junction box at the back side (FLPROJBB series), we do not recommend using a double-sides adhesive tape to mount the module, especially on uneven surfaces with irregularities. Instead, please use a suitable sealant / adhesive to glue the module, applying it on the back side of the module and also a sufficient amount of adhesive all the way around the junction box. This will ensure that the recess in the surface made for the junction box will remain waterproof.

DRILLING / SCREWING / RIVETING

It is only possible to drill through those modules for which it was declared at the time of order that they are supplied with a wider peripheral zone (edges) suitable for drilling. For such modules, it is important to allow a minimum of 12 mm distance to the nearest solar cell or electrical conductor.

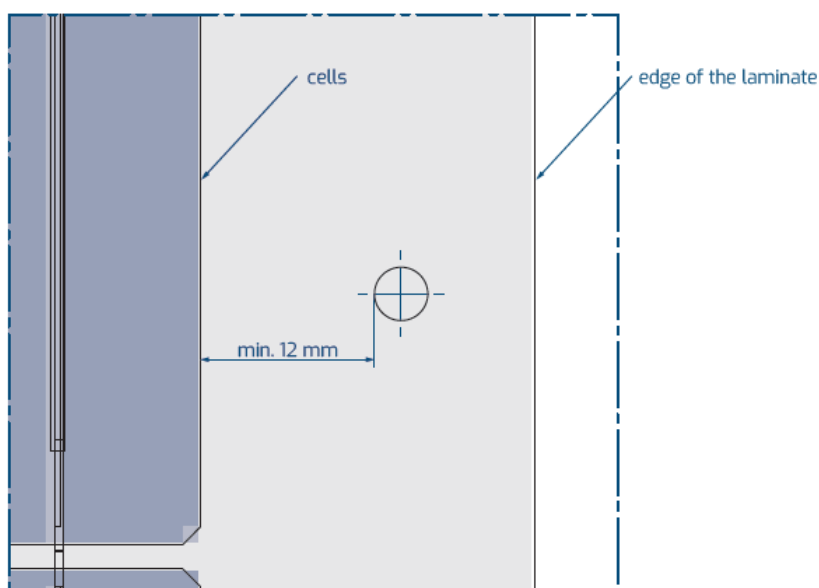

The edges of the cut holes should be sealed to prevent moisture from entering the fibre reinforced composite material. A suitable sealant for outdoor applications can be used. Note that inadequately sealed cut or drilled surfaces will void the warranty.

If your modules come with factory-installed eyelets, they can be used with appropriate quick-release fasteners or screws.

IV. ELECTRICAL INSTALLATION

A photovoltaic module behaves like a current generator (such as a battery) and therefore has a positive and a negative contact.

If several modules are connected together, the total voltage / current of the PV array must be below the maximum voltage / current of the inverter, solar charge controller or the maximum system voltage / current of other connected devices, cables and connectors. Please also note:

- The maximum module overcurrent protection rating of 20A needs to be taken into account when modules are connected in parallel.
- Do not connect modules with different orientation or angles of inclination in the same string.

The cables must have sufficient cross-section to avoid significant voltage drop. Always use specific cables for photovoltaic installations, resistant to atmospheric agents.

Warning! The modules have waterproof solar connectors on the end of the cable. You should never disconnect, remove or replace the connectors while the wires are active (solar module is under load). Connectors are only designed to be disconnected without any load.

Always keep the module connectors dry and clean. Any dirt, humidity or grease on connectors can increase resistance and degrade performance. For this reason, a clean installation environment is essential. Unconnected connectors must always be protected from dirt, humidity and weather conditions before the installation. If your connectors come with dust caps, you should only remove them just before the electrical installation.

Do not attempt to make an electrical connection with wet, soiled, or faulty connectors, as it may result in arcs and electric shock. Check that all electrical connections are securely fastened and connectors with locking mechanisms are fully locked.

Ensure that the cabling is not under stress. We recommend placing cables in cable ducts in order to have additional UV protection and prevention of cable pitch.

V. CLEANING AND CARE

Due to the special surface of Photonic Universe modules of FLPRO series, dirt and grime are usually washed away by rain. Nevertheless if the modules are fully or partially shaded by dirt or debris they need to be cleaned to prevent a loss of performance.

Clean the front side of the module using a soft cloth (dry or moist with lukewarm water). Do not use tensides, scrapers, or any high pressure water tools. Never use any greasy substance or a metal tool.

In areas with low winter temperatures, remove snow and ice without force (e.g. with a very soft broom) to avoid causing damage to the protective layer of the photovoltaic module.

Inspect the modules at least once a year to ensure that all connections and fixings are tight and corrosion free.