SWM Series

— Module MPPT Wind Solar Hybrid Controller

User Manual



Product Model
HCM400-12-12

Contents

1. Important Safety Warning	1
2. Basic Information	1
2.1 Introduction and Features	1
2.2 Product Structure	2
3. Product Installation	3
3.1 Installation Notes	3
3.2 Installation and Wiring.....	3
3.2.1 Installation Steps.....	3
3.2.2 Electrical Connection.....	4
4. Operation Interface Introduction	6
4.1 LCD Display	6
4.2 LCD Information Define.....	7
5. Trouble Shooting	10
6. Technical Parameters	11
7. Warranty	13

1. Important Safety Warning

Before Using the controller, please read all instructions and cautionary markings on the unit and this manual. Save the manual where it can easily be accessed.

This manual includes all safety warnings, installation, and operation guidance of SWM series wind&solar hybrid controllers.

- Before installing and using this controller, read all instructions and cautionary markings on the controller and all appropriate sections of this guide.
- Do not disassemble the machine, change the electrical components and parts yourself, or we will not responsible for the warranty items and related duties.
- To avoid a risk of fire and electric shock, make sure the existing wiring is in good condition and that the wire is connected tightly.
- Do not restart the controller immediately after it alarms. Please analyze the fault reasons and repair them at first, and then restart the controller until the fault is solved.

2. Basic Information

2.1 Introduction and Features

SWM series wind solar hybrid controller integrates the wind MPPT control, PV control and battery charge and discharge function in one machine.

Features:

- Recognize 12V/24V Battery automatically
- Wind turbine MPPT track point adjustable
- Electronic components in high quality
- Complete protection function
- Solar and wind generation capacity and electricity consumption visible.
- Seven modes of load output optional.

- RS232/RS485/RJ45/GPRS/Bluetooth/Zigbee monitoring modes optional
- Compatible with standard MODBUS communication protocol

2.2 Product Structure

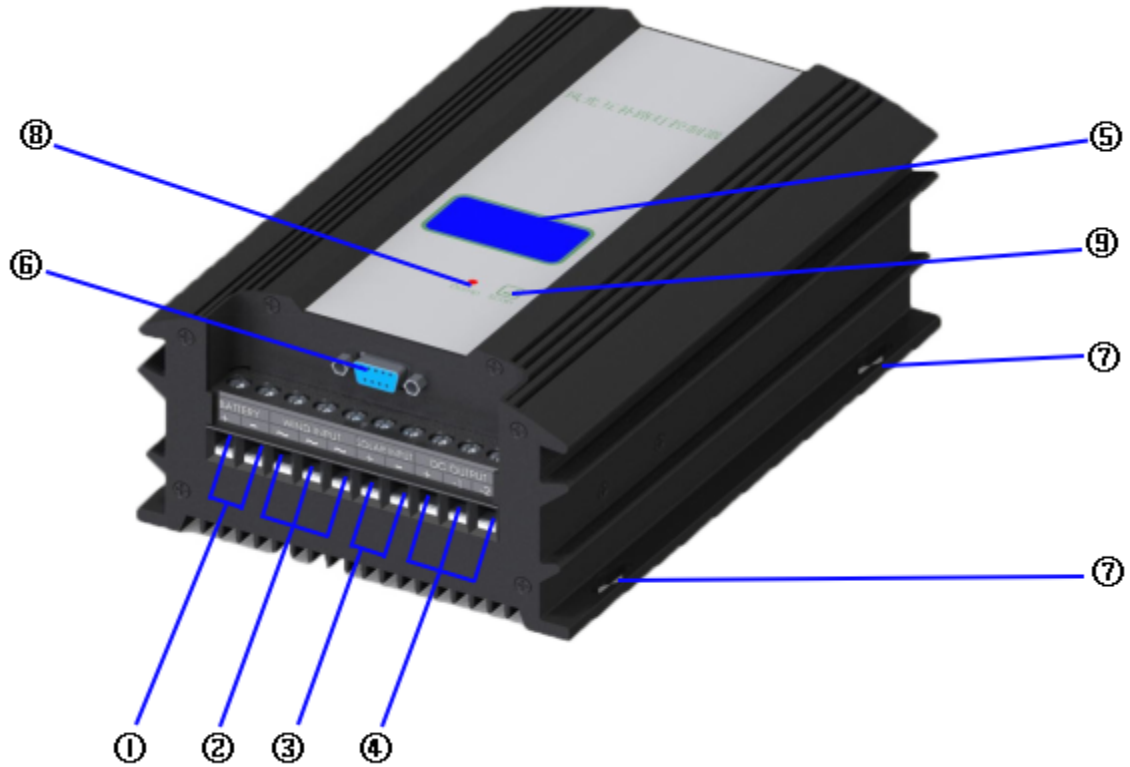

Chart1. Product Overview

①	Battery terminal	⑥	Communication port
②	Wind turbine terminal	⑦	M4 screw install hole
③	PV terminal		
④	Load terminal	⑧	Dump load light
⑤	LCD Display	⑨	button

3. Product Installation

3.1 Installation Notes

- 1) The machine should be kept indoors and well ventilated;
- 2) Environment temperature: -20~+40°C; Humidity: ≤95%, no condensing
- 3) Altitude should not be more than 4000m. (>1000 m derating according to the GB/T3859.2 regulations)
- 4) Avoid using the machine in direct sunlight, sun exposure, rain, humidity, acid fog, and dust.
- 5) To guarantee the lifespan, it is suggested that the space around the device has no other items within 30CM.
- 6) The machine can only charge for the battery in the rated voltage range.
- 7) The machine can only be connected to the wind turbine and PV with allowed power and voltage.

3.2 Installation and Wiring

3.2.1 Installation Steps

Please refer to the specific installation situation. Generally speaking, if it is used in street light pole, you can fix the controller to the rail inside the light pole.

If it is installed in the power box, the power box is drilled according to the hole size, and the controller is fixed with M4 screw.

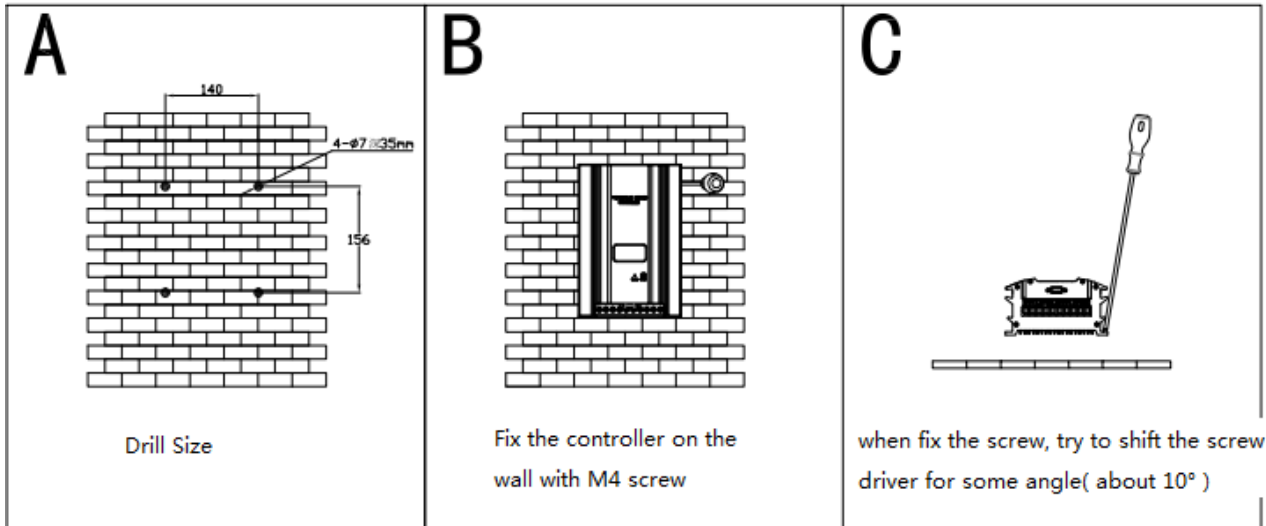

Chart 2: Installation Steps

3.2.2 Electrical Connection

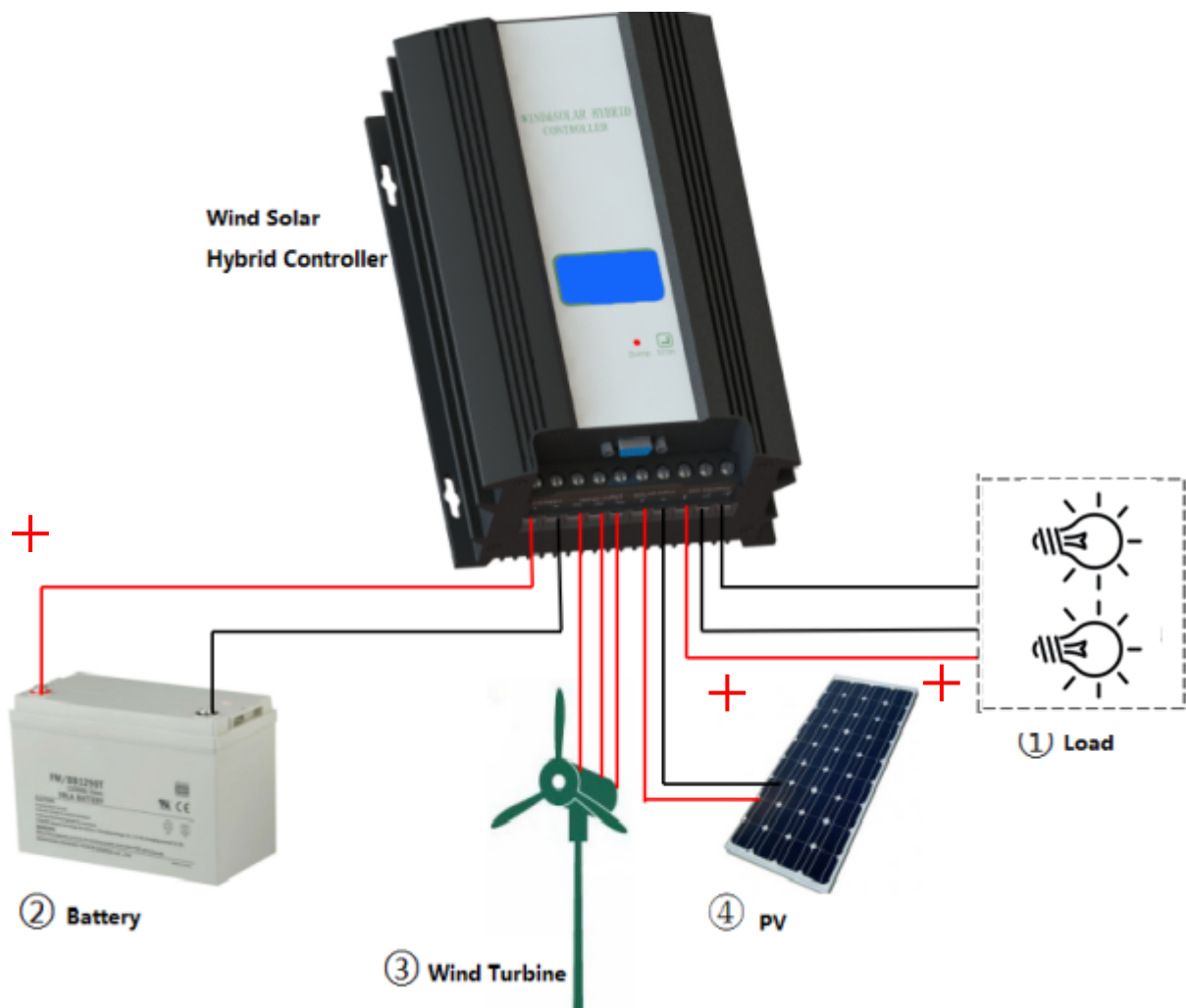

Chart 3: System Overview

Please connect those parts according to the order of ①②③④, and notice the following items.

1. Connect the load positive and negative terminal to the “DC OUTPUT” terminals as “+”“-1”“-2”relatively. 2 output loads share the same “+” terminal.
2. Connect the battery bank to the controller by the terminal which marks “BATTERY”. (do not reversed the connection of positive and negative terminals)
3. When wind turbine is still or running in a low speed, connects its output cable to the “WIND INPUT” terminal on the controller.
4. Connected the terminals of solar panels to “SOLAR INPUT” terminals “+”“-”on the controller;
5. Check all the connection to make sure they are connected rightly and tightly.

4. Operation Interface Introduction



4.1 LCD Display

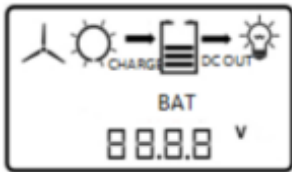
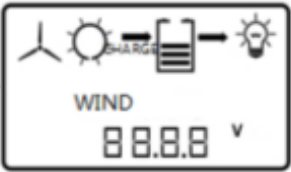
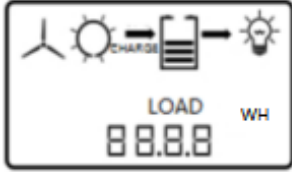
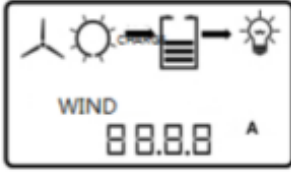
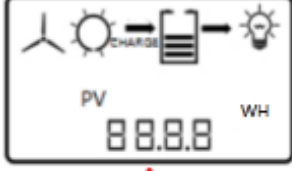
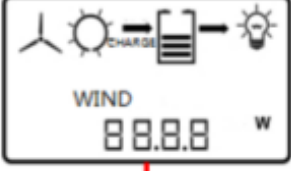
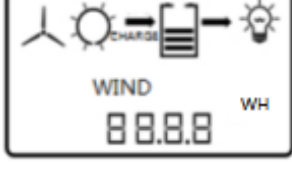
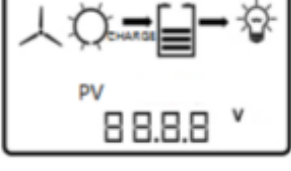

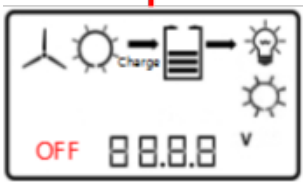
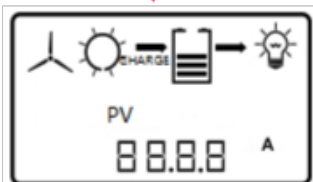
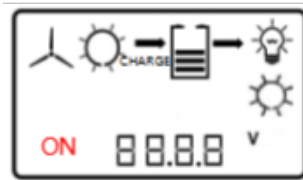
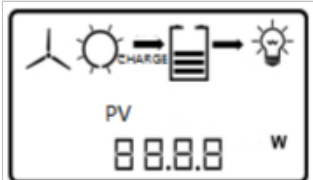
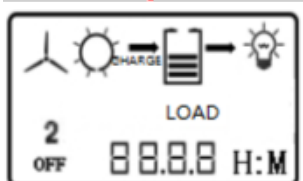
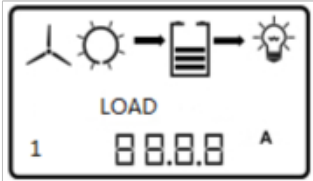
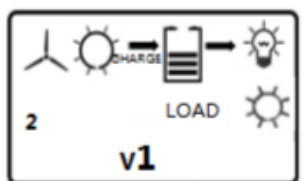
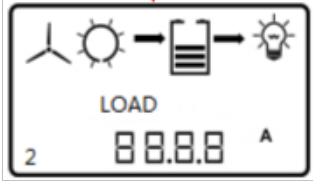
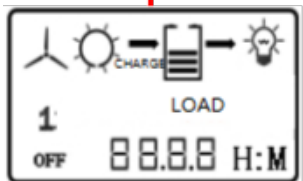
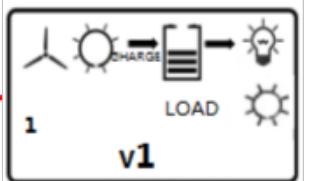



After the power is connected, the whole screen is in a browsing status. It shows battery voltage, and can be changed to the following information by press related buttons.

Interface Introduction	Display interface	Display interface	Interface Introduction
Battery Voltage			Wind turbine voltage
Accumulative total electricity consumption			Wind turbine current
Accumulative total Solar generation capacity			Wind turbine power
Accumulative total wind turbine generation capacity			PV voltage



Light control off voltage			PV current
Light control on voltage			PV power
Load 2 Control off time			Load 1 current
Load 2 output mode			Load 2 current
Load 1 off time			Load 1 output mode

4.2 LCD Information Define

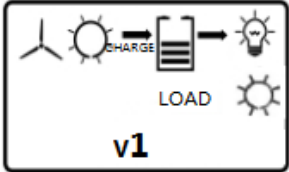
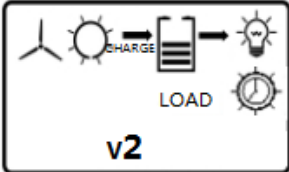
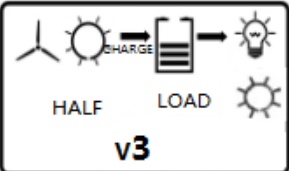
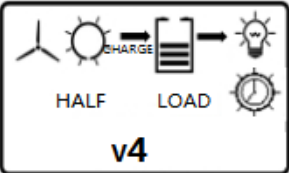
Name	Icon	Status
Wind Turbine		Rotate means wind turbine works normally
	BRAKE	Brake by hand
Solar		Day
		Night or PV is not connected

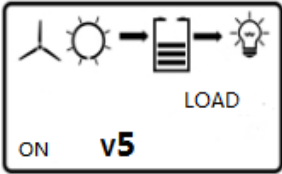
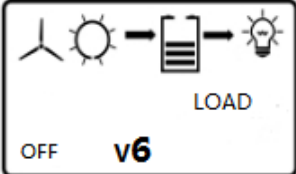
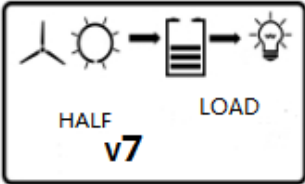
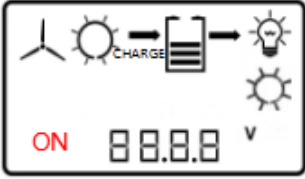
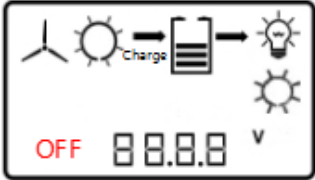
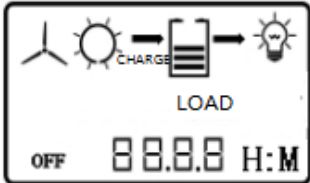
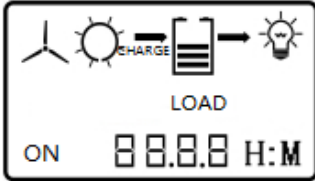
Battery		Battery
		Flickering means over voltage
		Flickering means over -discharge
Load		Output normally
		No output.
		Flickering means overload
		Flickering means short circuit
7 load output control modes		Light control on/off
		Light control on, time control off
		Light control on, time control half power, light control off
		Light control on, time control half power, time control off

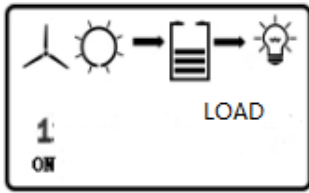
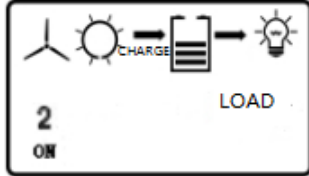
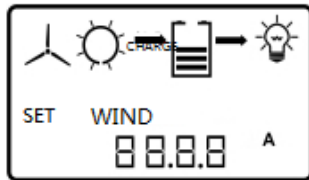
		Keep on
		Keep off
		Keep half power
Light control on/off voltage		Light control on voltage
		Light control off voltage
Time control time		Time control off time
		Time control half power time

Load		1st Load
		2nd Load
Power curve		Current at cut-in voltage or current at rated wind turbine voltage
Others		Parameters display
		“SET” icon. When it appears, you can set related parameters by press the scan button.

5. Trouble Shooting

Fault Type	Description	Possible reasons and solutions
No display on LCD	The connection between the battery and the controller is not tight	Check the wiring, and reconnect it.
	Battery is connected in wrong polarity to battery input terminals.	Need change the internal fuse in controller, and reconnect the battery.
No charging	The connection cable between wind turbine and controller is loose.	Reconnect the cable tightly.
	Wind turbine output voltage haven't reached the charging voltage,	Check whether the system voltage is reasonable.

	Wind turbine is in “Brake” status	Press the button for 5s to release the brake status if it is manual brake. Wait the wind turbine recover automatically(about 10 mins) if it brakes for other reasons.
	The connection cable between solar panel and controller is loose.	Reconnect the cable tightly.
	The Solar panel is connected negatively to the controller.	Reconnect the cable.
	PV output voltage is not in accordance with the system voltage.	Check the PV output and the system parameters.
No load output	Load over load	Check if the load connection is normal. Remove the over load , press the set button on the load interface to recover output
	Load short circuit	Check the load, and press the set button on the load interface to recover output
	Battery undervoltage for the second time	Check if the battery icon on the LCD display flickers. If yes, it needs about 4 hours to recover automatically, or cut off the power and reconnect again.

6. Technical Parameters

Model	HCM400-12-12
Wind Turbine Input	
Rated input power	400W
Rated input voltage	12V
Input voltage range	2~16V
Rated input current	34A
Manual Brake	Keep press the button for 5s to unload completely, and then recover by hand.

Brake by over current	34A (factory default,0~40A settable) unload completely when reached the set current, and recover automatically after 10 mins.
Brake by overvoltage	Refer to “output overvoltage” control
PV Input	
Rated input power	200W
Max. Open circuit voltage	24V
Rated input current	17A
Reversed connection protection	YES
Charge Parameters	
Rated battery voltage	12V
Output overvoltage point	14V
Output overvoltage recovery point	12.7V
DC Load Output	
Output loops	2 loops
Output control mode	Both 2 loops could be set in 7 modes, such as light control on&off, light control on and time control off.
Output voltage range	10.8V~16V
Undervoltage recovery point	Refer to "rated battery voltage"
Rated output current	10A/each loop
Overload protection	120% rated DC output -1min,150% rated DC output -10s
Short circuit protection	Instant protection
General Parameters	
Rectifier mode	Uncontrolled rectifier
Display mode	LCD
Display information	Battery voltage, wind turbine voltage/current/ power, PV power/voltage/current, light control on voltage, light control off voltage, time control duration, load current, wind power generation capacity,

	solar power generation capacity, load power consumption, and so on.
Monitoring mode (optional)	RS232
Monitoring Contents	Real-time display: Battery voltage, wind turbine voltage/current/ power, PV power/voltage/current, wind power generation capacity, solar power generation capacity, Battery status, wind turbine status, day and night, DC overload, DC load short circuit, and so on.
	Parameter setting: Output overvoltage point, wind turbine over current point, wind turbine start voltage, DC load overvoltage/undervoltage/undervoltage recovery point, output mode choice for two loops, light control on voltage, light control off voltage, and wind turbine brake settings.
Lightning protection	YES
Static loss	<0.6W
Ambient temperature	-20°C ~ +40°C
Humidity	0~90% ,No condensing
Noise	≤65dB
Cooling mode	Natural cooling
Installation mode	Wall-mounted
Cover protection class	IP52
Product dimension (W*H*D)	150×220×83mm
Product net weight	2.3kg
Note: Part of parameters can be adjusted according to customer's specific demand.	

7. Warranty

The product shall be in warranty for one year from production. Please take contract as the final one if it has special terms on warranty.