

Wind Turbine Generator

WTN Series

600W

Instruction Manual

CE / UKCA

Dear Customer,

Thank you very much for selecting this product.

This manual contains important information regarding the installation and operation of your wind turbine.

Please ensure that you read this manual carefully and in full, prior to installation. Please pay particular attention to the safety recommendations provided.

If you require any further information not provided in this user manual, please contact your supplier.

Contents

1. Product Overview	4
2. Safety Information	4
2.1 Prior to installation.....	4
2.2 After the installation	5
3. Package Contents.....	5
4. Site Considerations	5
5. Assembly and Installation	6
5.1 Unit assembly	7
5.2 Connection	9
5.3 Recommended cable size and type	9
6. Troubleshooting.....	10
6.1 Mechanical issues	10
6.2 Electrical issues	11
7. Maintenance.....	11
8. Technical Specifications	12
9. Warranty	12

1. Product Overview

This high quality wind turbine provides an ideal energy solution for both on-grid and off-grid applications for locations with medium to high wind speeds. This product can also be added to any existing system (for example a solar power system) to supplement charging and energy production.

Applications include, but are not limited to:

- Off-grid and hybrid household power systems
- Power for remote locations
- Telecommunications and power station equipment
- Power for industrial sites
- Lighting, farming etc

This wind turbine has been specifically engineered to maximise power generation whilst adhering to the highest standards of safety. In addition to the standard braking and safety features, this wind turbine also includes an innovative *aerodynamic braking tail mechanism*, which forces the turbine to move away from the wind direction at high winds to reduce the speed of rotation and prevent damage to the generator.

2. Safety Information

Safety should be the primary concern during the assembly, installation and operation of your wind turbine. Ensure that you are fully aware of the risks involved with mechanical and electrical installation work.

If in doubt concerning any issue relating to your wind turbine, always seek further assistance before proceeding. Installation of the turbine should only be undertaken by competent and qualified personnel.

2.1 Prior to installation

- Avoid installing the wind turbine on a windy day.
- Wear appropriate gloves and other protective wear.
- Never open the turbine enclosure or disassemble the generator.
- Follow all precautions and requirements for works at height.

2.2 After the installation

- When the wind turbine is in operation, avoid being underneath it or in close proximity to the wind turbine pole (e.g. for a 6m pole, maintain a safe distance of at least 7m from the wind turbine).
- Do not disconnect the wind turbine from the controller / inverter in high wind or severe weather conditions. Disconnection of the wind turbine disables the electromagnetic braking mechanism. Without it, high winds might cause the wind turbine to start rotating abnormally fast, which might lead to overheating and damage of the bearing and the generator.
- Before the expected arrival of a storm, hurricane or another severe weather event, it is recommended that the wind turbine tower is lowered, tipped or the wind turbine / the hub with blades is removed, to prevent damage or loss. Do not solely rely on the aerodynamic tail furling as it might not be enough in extreme weather conditions.

3. Package Contents

Important: upon receipt of the item package, an immediate check should be performed, confirming that all items are present and in good condition. The following components should normally be supplied for your wind turbine:

Product Name	Packaging material	Contents	Quantity
Generator	Plywood or carton	Turbine Head	1
		Flange	1
		Hub	1
		Tail Rudder	1
		Bolt/Nut	1
Blades	Plywood or carton	Blade	3
		Tail	1

4. Site Considerations

1. The ideal location for a wind turbine has good and regular or constant winds.
2. Please note that the wind speed increases at higher altitudes and consequently, power production will also be greater. It is therefore recommended that the wind turbine is installed as high as possible. A height of around 6m above ground in an open location normally achieves good energy production.
3. Each installation is affected by the following factors:
 - Pole / tower height

- Distance from the controller, inverter or battery bank
- Obstacles such as buildings and trees

Ideal positioning involves maximising the tower height, wind speed and distance from obstacles, whilst minimising the distance from the controller, inverter or battery bank.

4. Consider the mounting of your turbine. Wind turbines must be fixed appropriately to a rigid elevated structure such as a part of a building or a dedicated pole or tower. There should be no mechanical obstacles on the way of wind turbine blades or anything which would prevent rotation of the wind turbine around the vertical axis.
5. When the wind turbine is mounted on a pole / tower, this structure must be properly secured (e.g. guy wires, anchors, foundation etc) in a fixed position. Make sure that your tower or pole is always constructed of metal. Do not use any timber, plastic or any other soft materials for the tower.

5. Assembly and Installation

The below diagram shows an expanded view of the wind turbine:

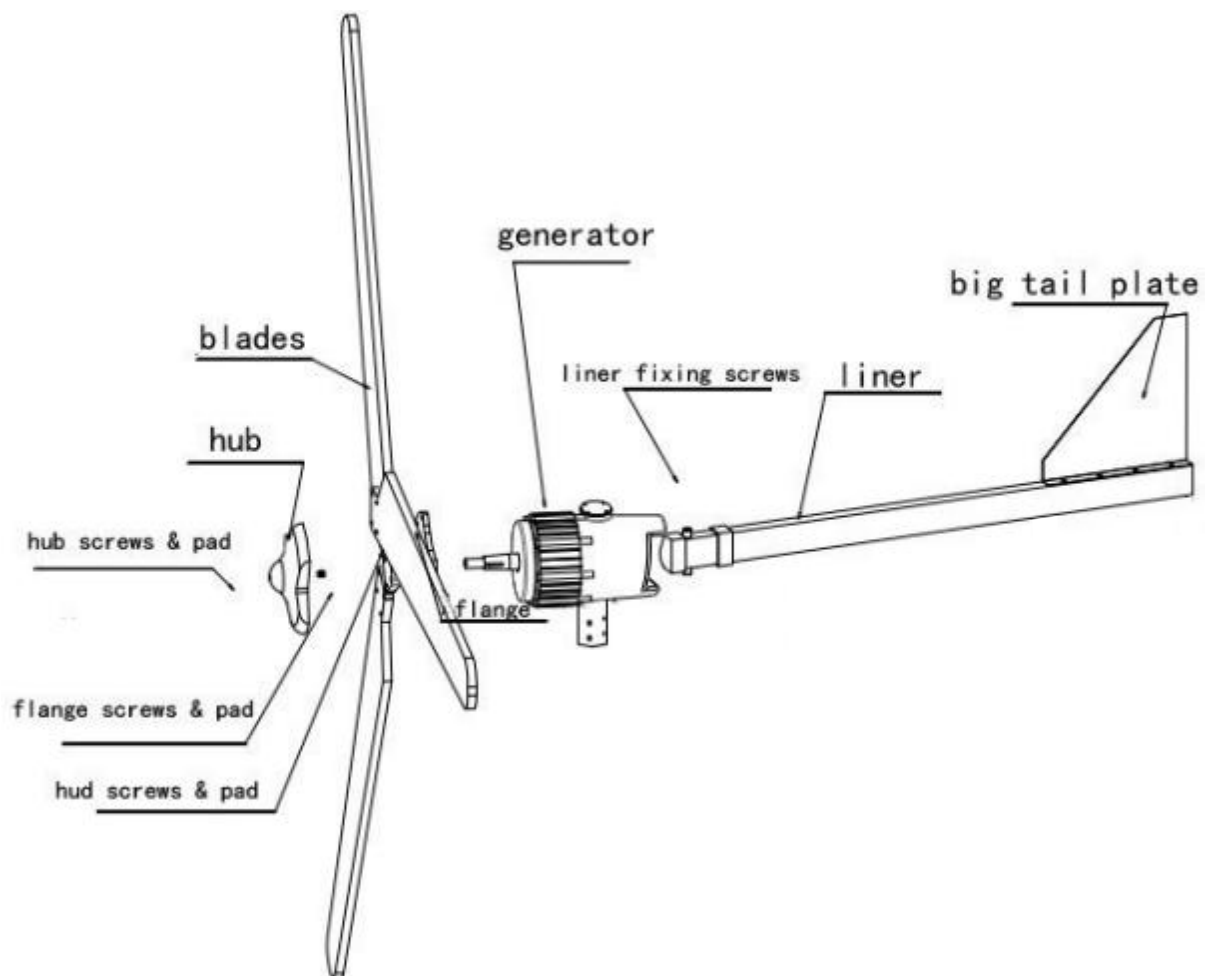

5.1 Unit assembly

1. Keep the tower close to the ground while performing the installation. The best method is to rest the top of the tower on a wooden shelf at a height of 1 to 1.5 metres, and attach the wind turbine to the tower, as shown below:

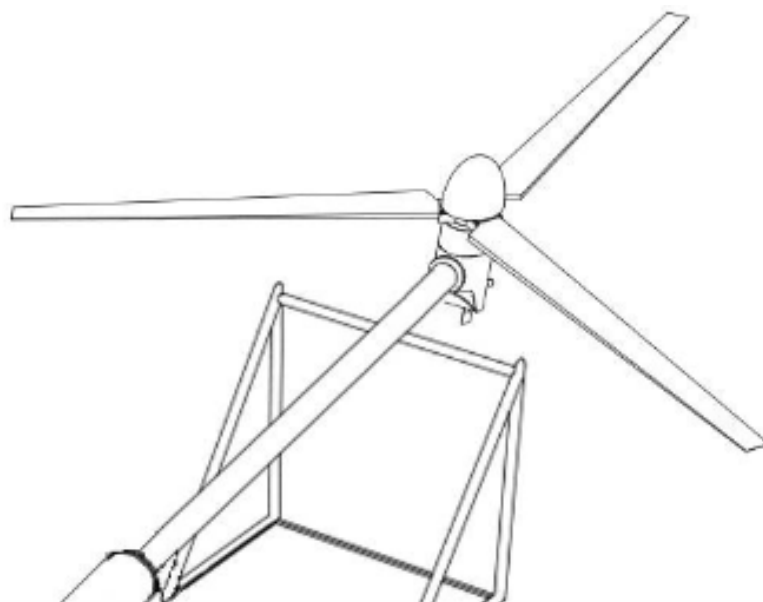

2. Fix the detachable part of the wind turbine connector to the top of tower by welding. Ensure that the centre line of the tower is parallel to the centre line of the casing when welding. Put the wind turbine head in the tower casing, and secure using the side screws.

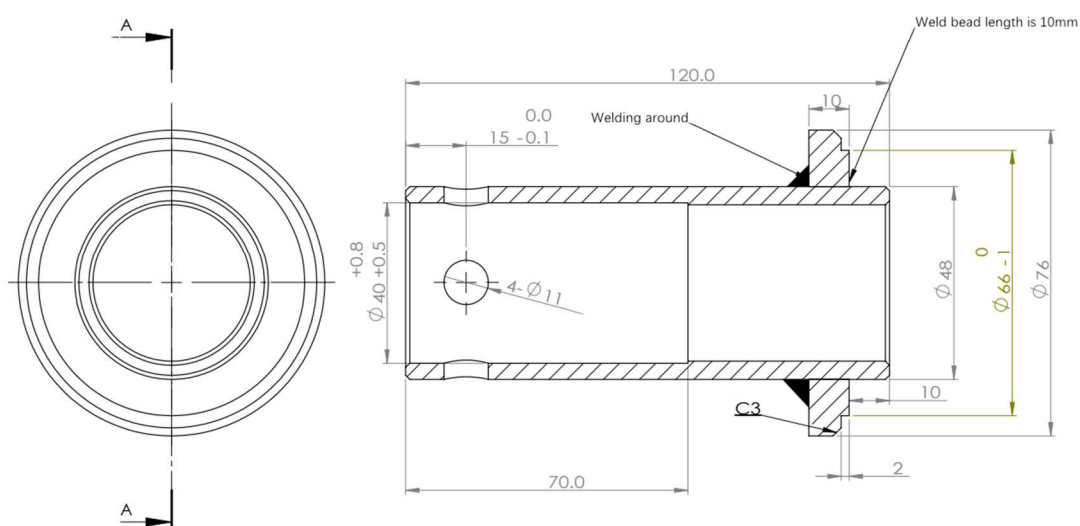

3. Pass the extension cables down through the top of the tower, and feed the cables out through the bottom.

4. Connect the extension cables to the wind turbine cables and insulate properly. Important: make sure the whole weight of the extension cable is not hanging on this connection point. Fix the extension cables to the tower not lower than 200mm below the connection point.
5. Attach the blades and then tighten the bolts. Please pay attention to balance when installing the wind blades. Do not tighten the bolts yet, as the length of the blades will need to be adjusted to match the diagram below:

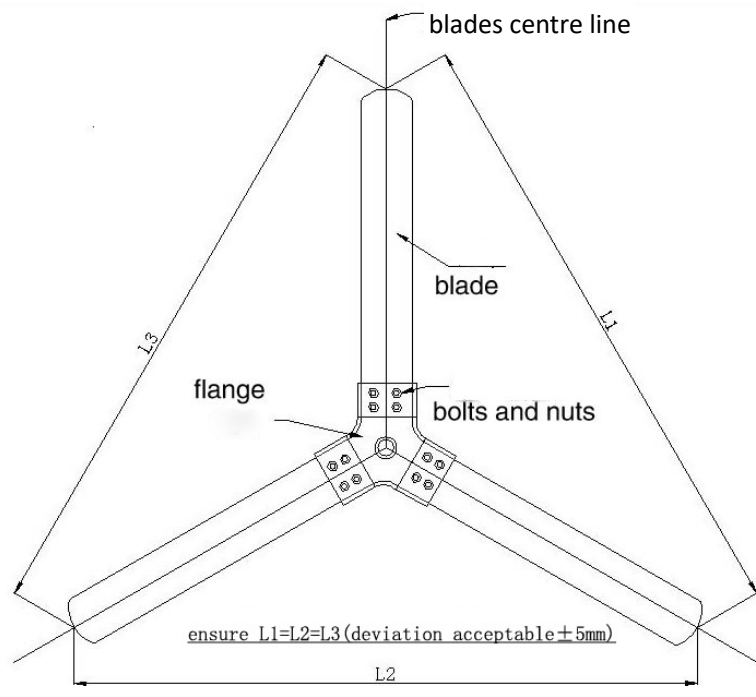

Note: if the distance between the tops of the blades in your installation exceeds the acceptable deviation, this may cause potential damages to the blades or flanges. If such damages are incurred, they will not be covered by the warranty.

6. Adjust the distance between the blades and tighten the bolts fully in the order shown below.

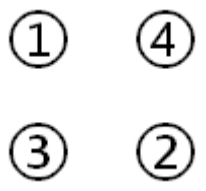

7. Place the front cone cover and secure it with bolts.
8. Position the tower upright and secure it appropriately (you may use guy wires, tensioners, concrete foundations, anchors etc)

5.2 Connection

1. When connecting the wind turbine to a charge controller, always follow the user manual and other technical documentation of the charge controller. Typically charge controller manuals require connection of the controller to the battery first (via an appropriately rated fuse), before the wind turbine is connected to the controller.
2. Connect the three output wires of the wind turbine to the controller wind terminals. Note: the output of the wind turbine is 3-phase AC, with no specific polarity, so the order of connection of these three wires is not important.
3. When connecting the wind turbine to an inverter, always follow the inverter manual and technical documentation.
4. You will need to extend the wires from the wind turbine to the controller / inverter. In order to attach the extension cable to the wind turbine wires, we recommend using robust connection methods (soldering, butt connectors or a screw terminal block). Make sure that each of the three wire joints is appropriately insulated.
5. Normally wind turbine cables run inside the wind turbine pole / tower. If there is a risk that the joints between the extension cable and the wind turbine wires would be exposed to water, humidity or condensation, we recommend using a connection method which provides a good environmental seal (e.g. adhesive lined heat shrink over soldering, butt connectors with heat shrink, non-crimp solder sleeves with heat shrink, waterproof cable joint covers etc)
6. Avoid using plugs and sockets for connection, unless they are waterproof and can be securely fixed when joined together.
7. Make sure the extension cables do not hang down on the connection point with all their weight. Fix the extension cables to the wind turbine pole mechanically in multiple locations.
8. It is recommended that any cables or wires at risk from outdoor exposure damage are sheathed with conduit for protection.

5.3 Recommended cable size and type

Using the appropriately rated wire is crucial to minimise system power losses caused by the resistance in the cables. The thickness of cable required depends upon factors such as the size of the wind turbine and the distance between the turbine and controller / inverter.

Quality of cable insulation, flexibility of the cable and resistance to environmental factors are also important. To minimise corrosion, a tinned copper cable normally provides great results. Additional cable conduit is recommended if there's a risk of cable movement or damage.

Please contact your supplier for advice on the thickness and grade of cable depending on the length and specific factors of your installation.

6. Troubleshooting

6.1 Mechanical issues

Potential issue #1:

The wind turbine is vibrating.

Possible causes:

1. The mounting bolts on the blades have become loose and must be tightened.
2. The blade surface is covered in frost / ice which must be removed.
3. The blades are defected or have become distorted and must be replaced.
4. The tower is not strong enough or the guy ropes are loose. Reinforce the tower and/or tighten the guy ropes.
5. The wind turbine is not operating in all phases. Check whether the three-phase output voltage is balanced by testing with a multimeter.

Potential issue #2:

The wind turbine is fixed in one direction and doesn't face the prevailing wind direction.

Possible causes:

1. The turbine alternator shaft is damaged, or the tower is not vertical.
2. The tower flange is not aligned with the flange on turbine, causing interference when the wind turbine attempts to change direction. Firstly, check that the turbine flange appears as shown in the user manual diagram. Secondly, check whether the turbine is loose, and whether the axis of rotation is being obstructed by the tower.

Potential issue #3:

The wind turbine is swinging or constantly rotating.

Possible causes:

1. Wind turbulence caused by natural factors. This is normal.
2. Wind turbulence caused by improper location of the turbine (i.e. buildings). Re-locate the wind turbine to a more appropriately suited location.

Potential issue #4:

The wind turbine rotation speed decreases in high wind.

Possible causes:

1. Normal deceleration, caused by the over-speed protection functions of the wind turbine. Safety functions such as dump load, electromagnetic braking and

aerodynamic braking are methods used to protect the system in high winds, and turbine deceleration is expected.

2. Abnormal deceleration (also observable in low and medium wind speeds) coupled with output problems, due to various mechanical reasons such as: friction between the rotor and stator, damaged bearings, a burnt generator, deformed/ damaged blades. If any of these situations is confirmed, please disconnect the wind turbine from the controller / inverter, remove it from the pole and contact your supplier for further assistance.

6.2 Electrical issues

Potential issue:

The wind turbine generator is producing an abnormal AC output.

Possible causes:

1. Low voltage caused by the inappropriate wire size (either too long or too thin). Replace the wiring with the thicker and higher grade cable and consider reducing the length.
2. Low voltage caused by a connection issue. Examine the connection point between the wind turbine wires and the extension cable and reconnect if necessary.
3. The generator three-phase output voltage is unbalanced. Imbalances in voltage should not exceed 10% (same wind speed or rotational speed). If exceeded, please contact your supplier.

7. Maintenance

Wind turbines are likely to encounter a variety of harsh or complex weather conditions and therefore require regular inspection and maintenance to maintain normal system operation. Please adhere to the following guidelines to perform maintenance approximately **once a year** to ensure a long-term optimal operation:

1. Regularly check the blades for signs of damage or imbalances. Such problems may lead to decreased blade efficiency.
2. Ensure that the bearings are sufficiently lubricated and apply grease if required.
3. Regularly check that all nuts, bolts and screws are secured well and are in good condition. If found to be loose, they must be tightened. If there is corrosion or loss, they must be replaced.
4. Regularly check all cables for damage, corrosion or poor contact. Resolve any abnormalities if possible or replace the cable if needed.
5. If the turbine is located in an area where the temperature falls below -20°C in winter, the lubricant on bearings must be replaced before and after the winter period. Use lubricants with a different viscosity for cold winter temperatures.

6. Regularly check that your charge controller / inverter system that it is working normally, with the necessary protection functions (such as braking) operating as intended.

8. Technical Specifications

WTN Series Wind Turbines	
Model	WTN600-24
Rated Power (W)	600
Rotor Voltage (V)	24
Rotor diameter (m)	2.1
Start-up Wind Speed (m/s)	2.5
Rated Wind Speed (m/s)	8
Shell Material	Die-cast Aluminium
Blade Material	High-strength Nylon Composite

9. Warranty

This wind turbine is covered by a 1 year warranty which starts from the day of delivery. The warranty covers defects of production, manufacturing or materials of the wind turbine.

The warranty does not cover:

- improper installation, misuse, mishandling, modification of the unit
- mechanical damages of the blades, generator or any other parts of the wind turbine, whether from airborne debris / collisions or due to any other reasons
- overheating, overcurrent, burning and similar effects of abnormally high winds or a severe weather event
- vibration, including caused by misaligned blades of the wind turbine
- cable connection issues, detached or broken wires
- mounting or fixing of the wind turbine on the pole / tower and security of the installation